

VCRR N-Channel Enhancement Mode Power MOSFET

Description

The VCRR75H21 uses advanced trench technology and design to provide excellent $R_{DS(ON)}$ with low gate charge. It can be used in Automotive applications and a wide variety of other applications.

General Features

- $V_{DSS} = 75V, I_D = 210A$
 $R_{DS(ON)} < 4m\Omega @ V_{GS} = 10V$
- Good stability and uniformity with high E_{AS}
- Special process technology for high ESD capability
- High density cell design for ultra low R_{dson}
- Fully characterized avalanche voltage and current
- Excellent package for good heat dissipation

Application

- Automotive applications
- Hard switched and high frequency circuits
- Uninterruptible power supply

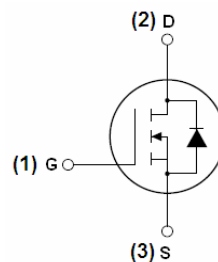

Schematic diagram

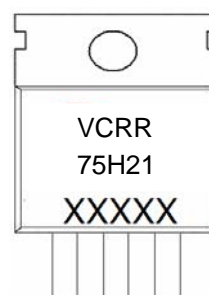

Marking and pin assignment

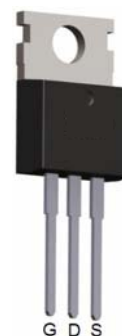

TO-220-3L top view

Package Marking and Ordering Information

| Device Marking | Device | Device Package |
|----------------|--------|----------------|
| VCRR75H21 | | TO-220-3L |

Absolute Maximum Ratings (TC=25°C unless otherwise noted)

| Parameter | Symbol | Limit | Unit |
|---|--------------------|-------|------|
| Drain-Source Voltage | V_{DSS} | 75 | V |
| Gate-Source Voltage | V_{GS} | ±20 | V |
| Drain Current-Continuous | I_D | 210 | A |
| Drain Current-Continuous($T_C = 100^\circ C$) | $I_D(100^\circ C)$ | 150 | A |
| Pulsed Drain Current | I_{DM} | 840 | A |
| Maximum Power Dissipation | P_D | 310 | W |
| Derating factor | | 2.07 | W/°C |
| Single pulse avalanche energy ^(Note 4) | E_{AS} | 2200 | mJ |

| | | | |
|--|----------------|------------|----|
| Operating Junction and Storage Temperature Range | T_J, T_{STG} | -55 To 175 | °C |
|--|----------------|------------|----|

Thermal Characteristic

| | | | |
|--|-----------------|------|------|
| Thermal Resistance, Junction-to-Case ^(Note 1) | $R_{\theta JC}$ | 0.48 | °C/W |
|--|-----------------|------|------|

Electrical Characteristics ($T_C=25^\circ\text{C}$ unless otherwise noted)

| Parameter | Symbol | Condition | Min | Typ | Max | Unit | |
|---|--------------|---|-----|-------|-----------|---------|------------|
| Off Characteristics | | | | | | | |
| Drain-Source Breakdown Voltage | BV_{DSS} | $V_{GS}=0V, I_D=250\mu A$ | 75 | | | V | |
| Zero Gate Voltage Drain Current | I_{DSS} | $V_{DS}=75V, V_{GS}=0V$ | | | 1 | μA | |
| Gate-Body Leakage Current | I_{GSS} | $V_{GS}=\pm 20V, V_{DS}=0V$ | | | ± 200 | nA | |
| On Characteristics | | | | | | | |
| Gate Threshold Voltage | $V_{GS(th)}$ | $V_{DS}=V_{GS}, I_D=250\mu A$ | 2 | 3 | 4 | V | |
| Drain-Source On-State Resistance | $R_{DS(on)}$ | $V_{GS}=10V, I_D=40A$ | | 25°C | 2.8 | 4 | m Ω |
| | | | | 125°C | 4.7 | 6.5 | m Ω |
| Forward Transconductance | g_{FS} | $V_{DS}=25V, I_D=40A$ | 100 | 165 | | S | |
| Dynamic Characteristics | | | | | | | |
| Input Capacitance | C_{iss} | $V_{DS}=25V, V_{GS}=0V,$ $F=1.0\text{MHz}$ | | 11000 | | PF | |
| Output Capacitance | C_{oss} | | | 914 | | PF | |
| Reverse Transfer Capacitance | C_{rss} | | | 695 | | PF | |
| Switching Characteristics | | | | | | | |
| Turn-on Delay Time | $t_{d(on)}$ | $V_{DD}=30V, I_D=2A, R_L=15\Omega$ $V_{GS}=10V, R_G=2.5\Omega$ | | 23 | | nS | |
| Turn-on Rise Time | t_r | | | 190 | | nS | |
| Turn-Off Delay Time | $t_{d(off)}$ | | | 130 | | nS | |
| Turn-Off Fall Time | t_f | | | 120 | | nS | |
| Total Gate Charge | Q_g | $I_D=30A, V_{DD}=30V, V_{GS}=10V$ | - | 250 | | nC | |
| Gate-Source Charge | Q_{gs} | | | 48 | | nC | |
| Gate-Drain Charge | Q_{gd} | | | 98 | | nC | |
| Drain-Source Diode Characteristics | | | | | | | |
| Diode Forward Voltage | V_{SD} | $V_{GS}=0V, I_S=40A$ | | | 1.2 | V | |
| Reverse Recovery Time | t_{rr} | $T_J = 25^\circ\text{C}, I_F = 40A$ $di/dt = 100A/\mu s^{(Note2)}$ | | 63 | | nS | |
| Reverse Recovery Charge | Q_{rr} | | | 98 | | nC | |
| Forward Turn-On Time | t_{on} | Intrinsic turn-on time is negligible (turn-on is dominated by LS+LD) | | | | | |

Notes:

1. Surface Mounted on FR4 Board, $t \leq 10$ sec.
2. Pulse Test: Pulse Width $\leq 400\mu s$, Duty Cycle $\leq 2\%$.
3. EAS condition: $T_J=25^\circ\text{C}, V_{DD}=37.5V, V_G=10V, L=2mH, R_g=25\Omega, I_{AS}=37A$

Test circuit

1) E_{AS} test Circuit

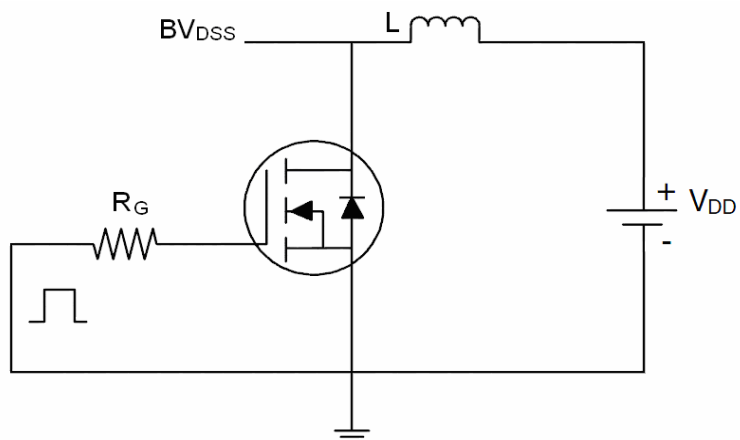

2) Gate charge test Circuit

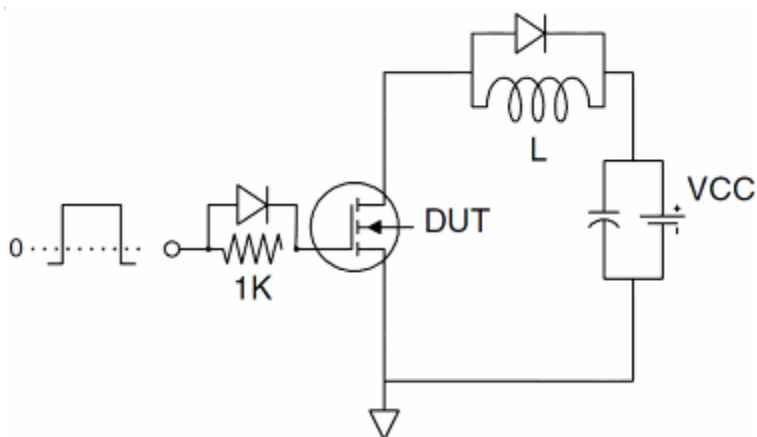

3) Switch Time Test Circuit

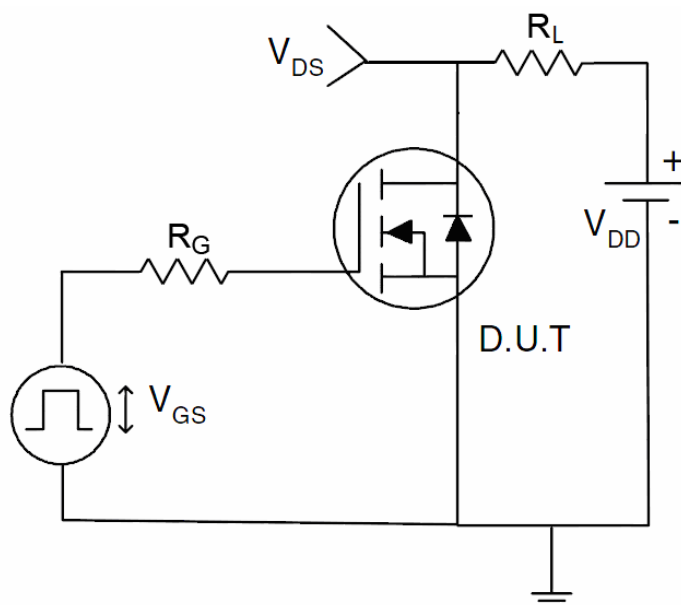

Typical Electrical and Thermal Characteristics

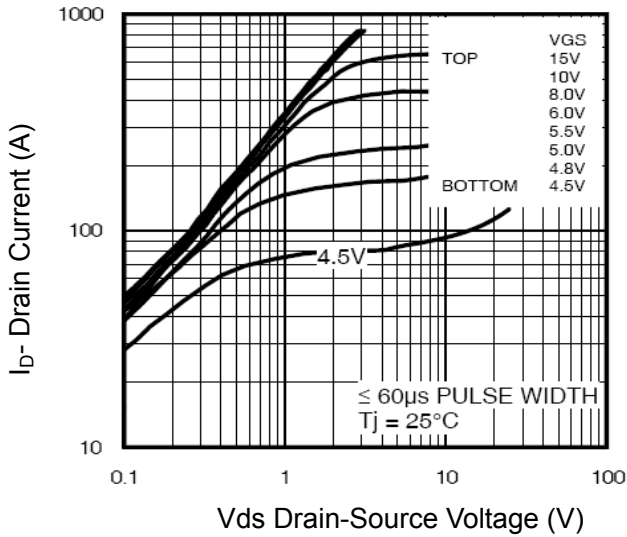

Figure 1 Output Characteristics

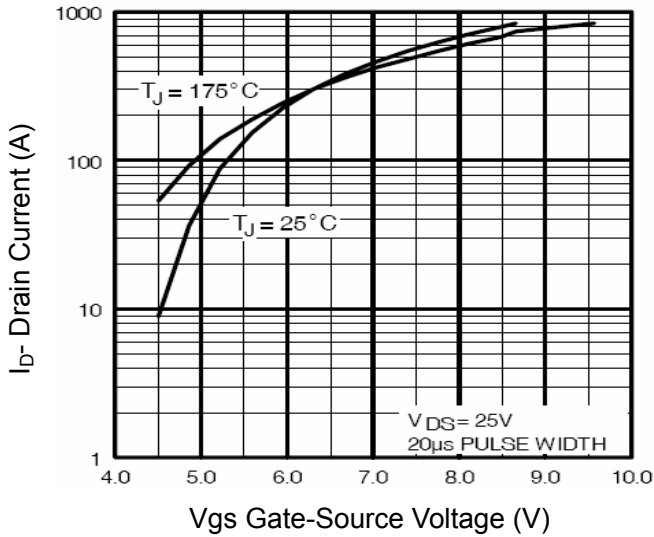

Figure 2 Transfer Characteristics

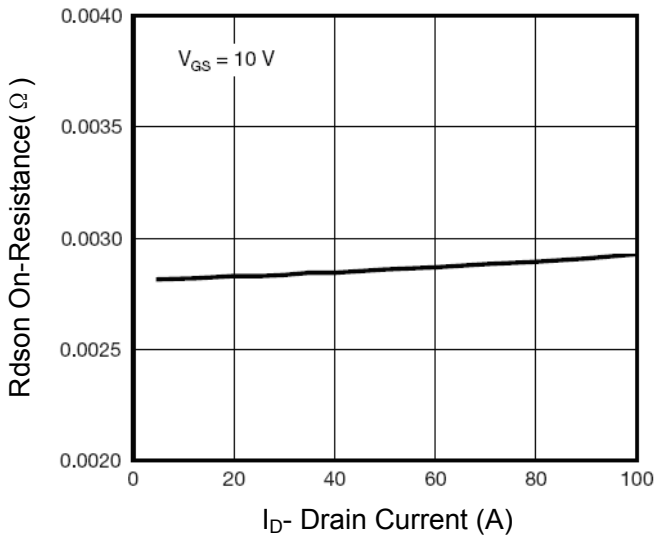

Figure 3 Rdson- Drain Current

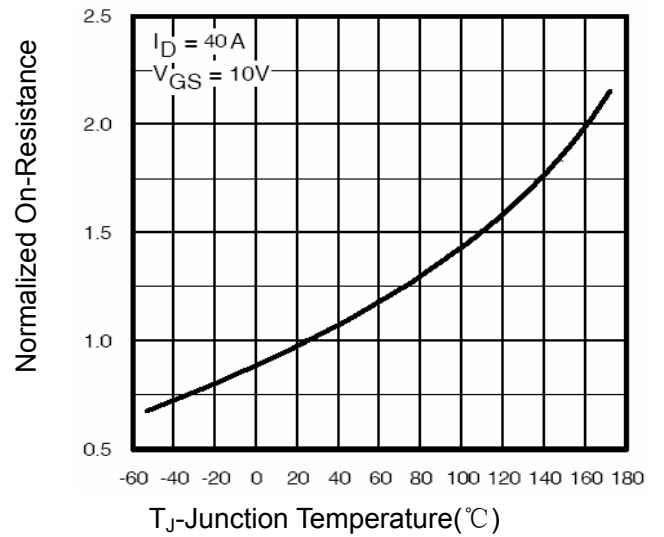

Figure 4 Rdson-Junction Temperature

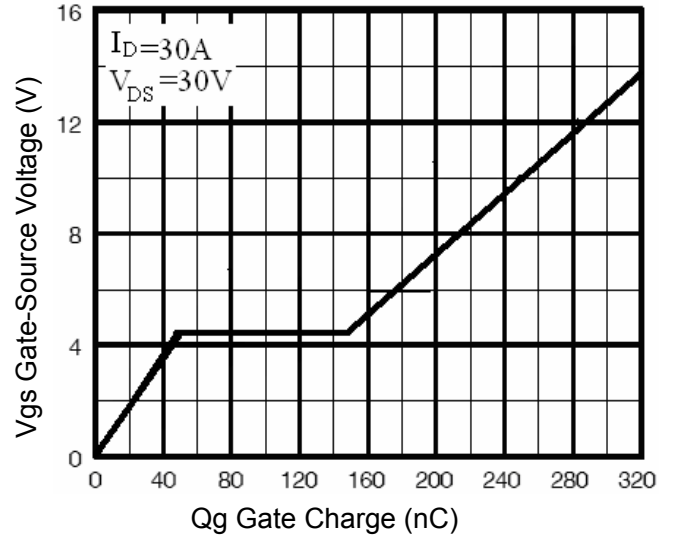

Figure 5 Gate Charge

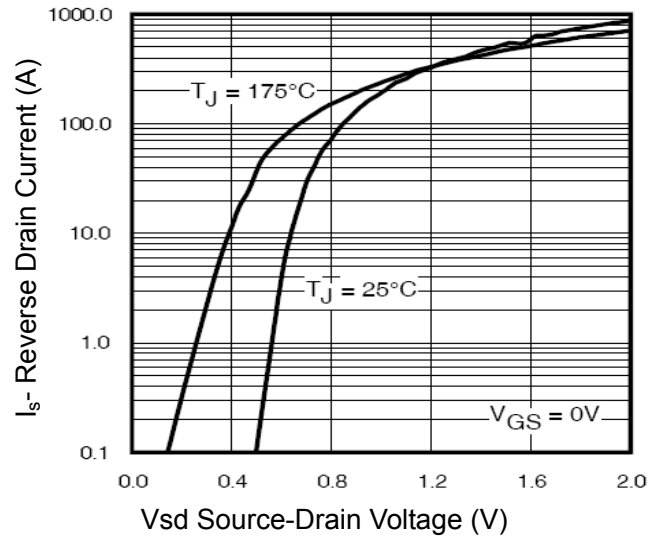

Figure 6 Source- Drain Diode Forward

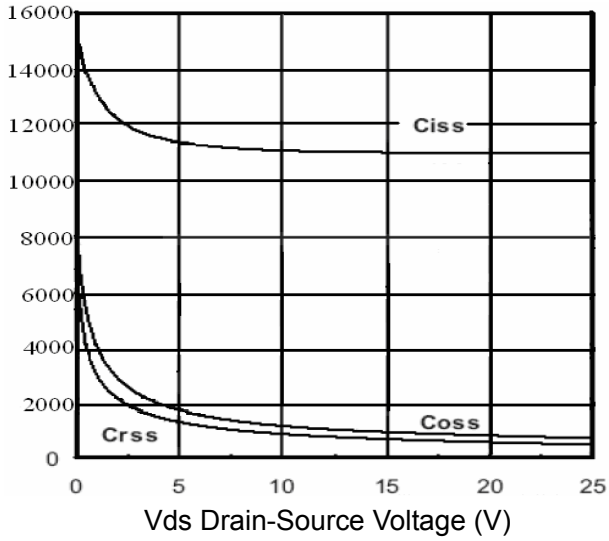

Figure 7 Capacitance vs Vds

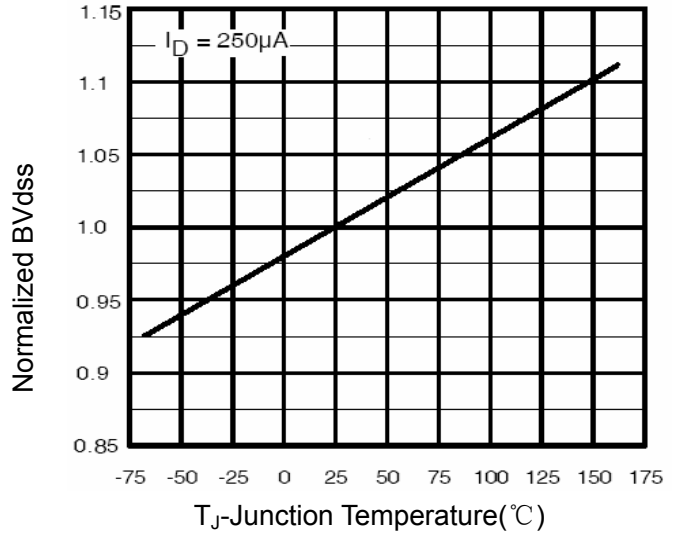

Figure 9 BV_{DSS} vs Junction Temperature

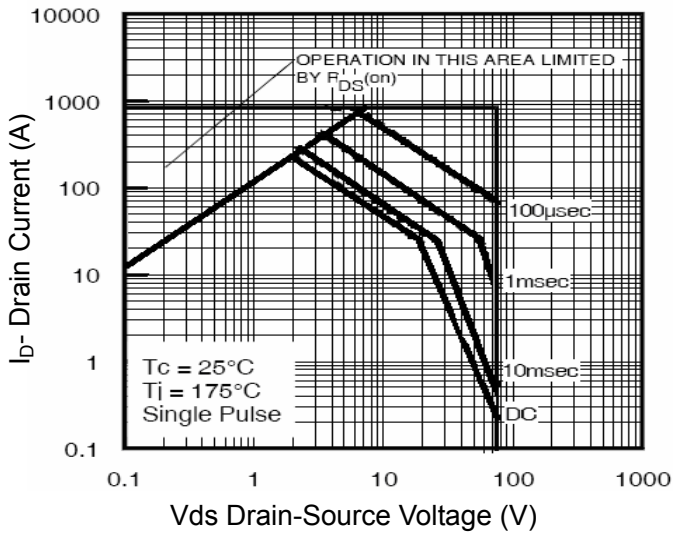

Figure 8 Safe Operation Area

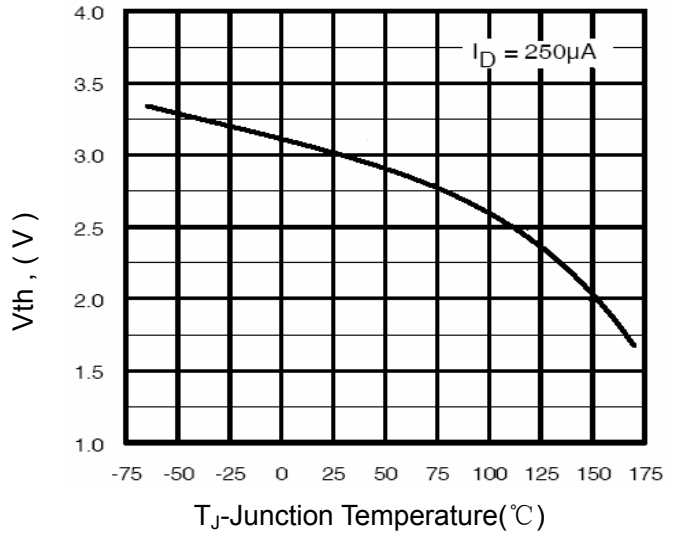

Figure 10 V_{GS(th)} vs Junction Temperature

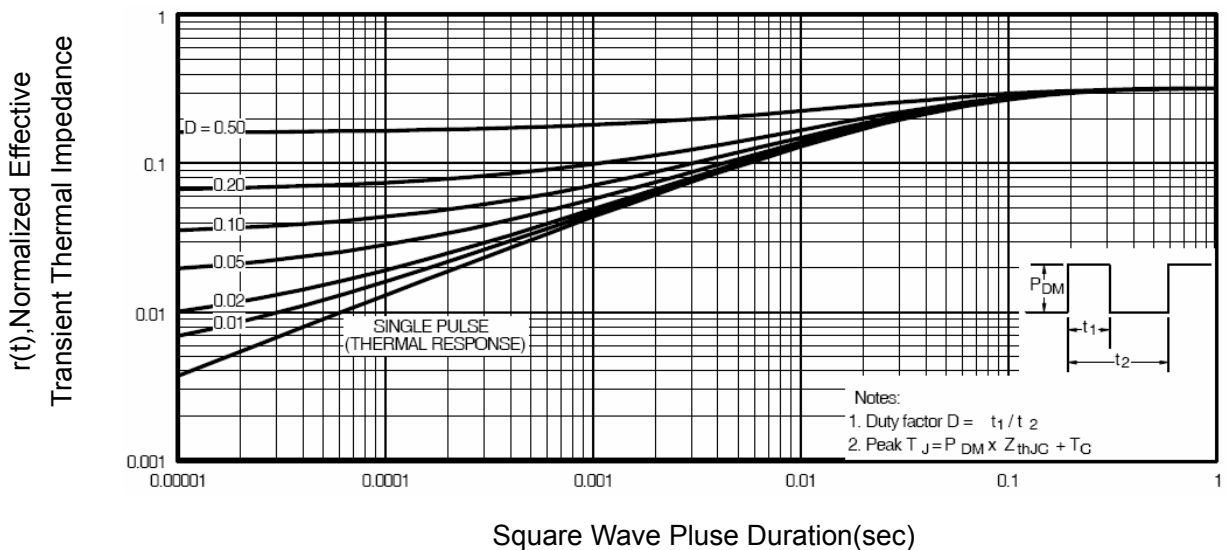
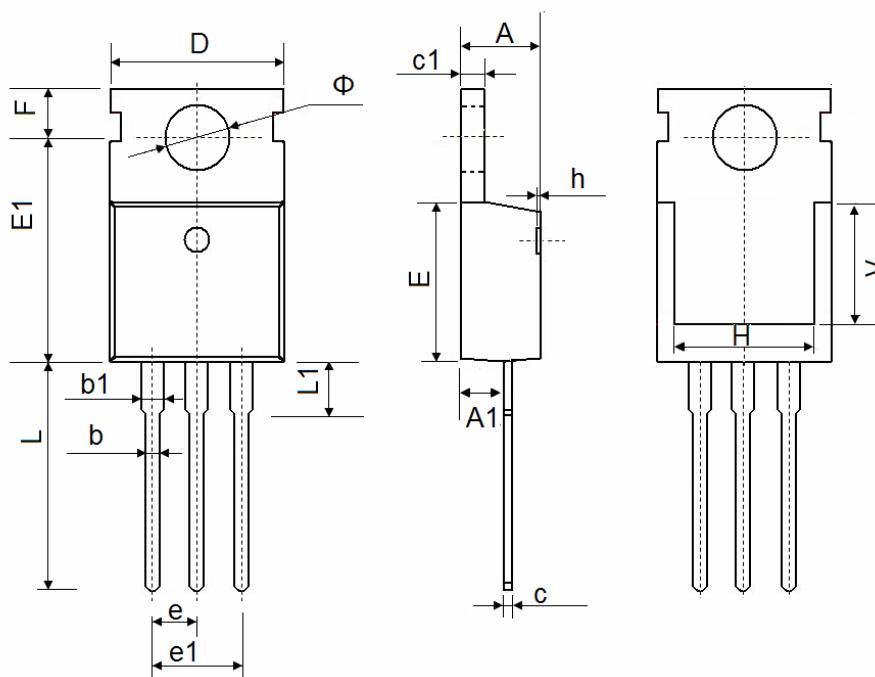

Figure 11 Normalized Maximum Transient Thermal Impedance

TO-220-3L Package Information



| Symbol | Dimensions In Millimeters | | Dimensions In Inches | |
|--------|---------------------------|--------|----------------------|-------|
| | Min. | Max. | Min. | Max. |
| A | 4.400 | 4.600 | 0.173 | 0.181 |
| A1 | 2.250 | 2.550 | 0.089 | 0.100 |
| b | 0.710 | 0.910 | 0.028 | 0.036 |
| b1 | 1.170 | 1.370 | 0.046 | 0.054 |
| c | 0.330 | 0.650 | 0.013 | 0.026 |
| c1 | 1.200 | 1.400 | 0.047 | 0.055 |
| D | 9.910 | 10.250 | 0.390 | 0.404 |
| E | 8.9500 | 9.750 | 0.352 | 0.384 |
| E1 | 12.650 | 12.950 | 0.498 | 0.510 |
| e | 2.540 TYP. | | 0.100 TYP. | |
| e1 | 4.980 | 5.180 | 0.196 | 0.204 |
| F | 2.650 | 2.950 | 0.104 | 0.116 |
| H | 7.900 | 8.100 | 0.311 | 0.319 |
| h | 0.000 | 0.300 | 0.000 | 0.012 |
| L | 12.900 | 13.400 | 0.508 | 0.528 |
| L1 | 2.850 | 3.250 | 0.112 | 0.128 |
| V | 7.500 REF. | | 0.295 REF. | |
| Φ | 3.400 | 3.800 | 0.134 | 0.150 |

Attention

QIAOXIN assumes no responsibility for equipment failures that result from using products at values that exceed, even momentarily, rated values (such as maximum ratings, operating condition ranges, or other parameters) listed in products specifications of any and all QIAOXIN products described or contained herein. QIAOXIN products are not designed for use in life support appliances, devices or systems where malfunction of these products can be reasonably expected to result in personal injury. Reproduction in whole or in part is prohibited without the prior written consent of the copyright owner. QIAOXIN reserves the right to make changes to information published in this document, including without limitation specifications and product descriptions, at any time and without notice. This document supersedes and replaces all information supplied prior to the publication hereof.