

QIAOXIN N-Channel Enhancement Mode Power MOSFET

Description

The VCRR1520KA uses advanced trench technology and design to provide excellent $R_{DS(ON)}$ with low gate charge. It can be used in a wide variety of applications.

General Features

- $V_{DS} = 150V, I_D = 20A$
 $R_{DS(ON)} < 75m\Omega @ V_{GS}=10V$ (Typ:62m Ω)
 $R_{DS(ON)} < 80m\Omega @ V_{GS}=4.5V$ (Typ:68m Ω)
- High density cell design for ultra low R_{dson}
- Fully characterized avalanche voltage and current
- Good stability and uniformity with high E_{AS}
- Excellent package for good heat dissipation

Application

- Boost converters
- LED backlighting
- Uninterruptible power supply

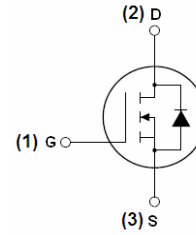

Schematic diagram

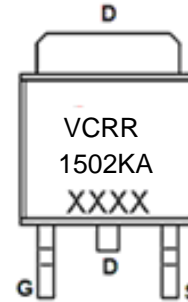

Marking and pin assignment

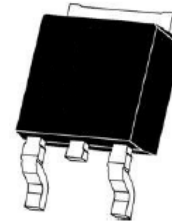

TO-252 -2L top view

Package Marking and Ordering Information

Device Marking	Device	Device Package	Reel Size	Tape width	Quantity
VCRR1520KA	VCRR1520KA	TO-252-2L	-	-	-

Absolute Maximum Ratings ($T_C=25^\circ C$ unless otherwise noted)

Symbol	Parameter	Limit	Unit
V_{DS}	Drain-Source Voltage	150	V
V_{GS}	Gate-Source Voltage	± 20	V
I_D	Drain Current-Continuous	20	A
$I_D(100^\circ C)$	Drain Current-Continuous($T_C=100^\circ C$)	14	A
I_{DM}	Pulsed Drain Current	40	A
P_D	Maximum Power Dissipation	90	W
	Derating factor	0.6	W/ $^\circ C$
E_{AS}	Single pulse avalanche energy ^(Note 5)	80	mJ
T_J, T_{STG}	Operating Junction and Storage Temperature Range	-55 To 175	$^\circ C$

Thermal Characteristic

$R_{\theta JC}$	Thermal Resistance, Junction-to-Case ^(Note 2)	1.7	$^{\circ}C/W$
-----------------	--	-----	---------------

Electrical Characteristics ($T_C=25^{\circ}C$ unless otherwise noted)

Symbol	Parameter	Condition	Min	Typ	Max	Unit
Off Characteristics						
BV_{DSS}	Drain-Source Breakdown Voltage	$V_{GS}=0V, I_D=250\mu A$	150	165	-	V
I_{DSS}	Zero Gate Voltage Drain Current	$V_{DS}=150V, V_{GS}=0V$	-	-	1	μA
I_{GSS}	Gate-Body Leakage Current	$V_{GS}=\pm 20V, V_{DS}=0V$	-	-	± 100	nA
On Characteristics ^(Note 3)						
$V_{GS(th)}$	Gate Threshold Voltage	$V_{DS}=V_{GS}, I_D=250\mu A$	1.2	1.6	2.5	V
$R_{DS(on)}$	Drain-Source On-State Resistance	$V_{GS}=10V, I_D=10A$	-	62	75	m Ω
		$V_{GS}=4.5V, I_D=10A$	-	68	80	m Ω
g_{FS}	Forward Transconductance	$V_{DS}=5V, I_D=10A$	-	20	-	S
Dynamic Characteristics ^(Note 4)						
C_{iss}	Input Capacitance	$V_{DS}=75V, V_{GS}=0V,$ $F=1.0MHz$	-	2500	-	PF
C_{oss}	Output Capacitance		-	68	-	PF
C_{rss}	Reverse Transfer Capacitance		-	54	-	PF
Switching Characteristics ^(Note 4)						
$t_{d(on)}$	Turn-on Delay Time	$V_{DD}=75V, R_L=5\Omega$ $V_{GS}=10V, R_{GEN}=3\Omega$	-	18.5	-	nS
t_r	Turn-on Rise Time		-	10	-	nS
$t_{d(off)}$	Turn-Off Delay Time		-	22	-	nS
t_f	Turn-Off Fall Time		-	8	-	nS
Q_g	Total Gate Charge	$V_{DS}=75V, I_D=10A,$ $V_{GS}=10V$	-	60	-	nC
Q_{gs}	Gate-Source Charge		-	7.1	-	nC
Q_{gd}	Gate-Drain Charge		-	17	-	nC
Drain-Source Diode Characteristics						
V_{SD}	Diode Forward Voltage ^(Note 3)	$V_{GS}=0V, I_S=20A$	-	-	1.2	V
I_S	Diode Forward Current ^(Note 2)	-	-	-	20	A
t_{rr}	Reverse Recovery Time	$T_J = 25^{\circ}C, I_F = 10A$ $di/dt = 100A/\mu s$ ^(Note 3)	-	34	-	nS
Q_{rr}	Reverse Recovery Charge		-	55	-	nC
t_{on}	Forward Turn-On Time	Intrinsic turn-on time is negligible (turn-on is dominated by LS+LD)				

Notes:

1. Repetitive Rating: Pulse width limited by maximum junction temperature.
2. Surface Mounted on FR4 Board, $t \leq 10$ sec.
3. Pulse Test: Pulse Width $\leq 300\mu s$, Duty Cycle $\leq 2\%$.
4. Guaranteed by design, not subject to production
5. EAS condition: $T_J=25^{\circ}C, V_{DD}=50V, V_G=10V, L=0.5mH, R_g=25\Omega$

Test Circuit

1) E_{AS} Test Circuit

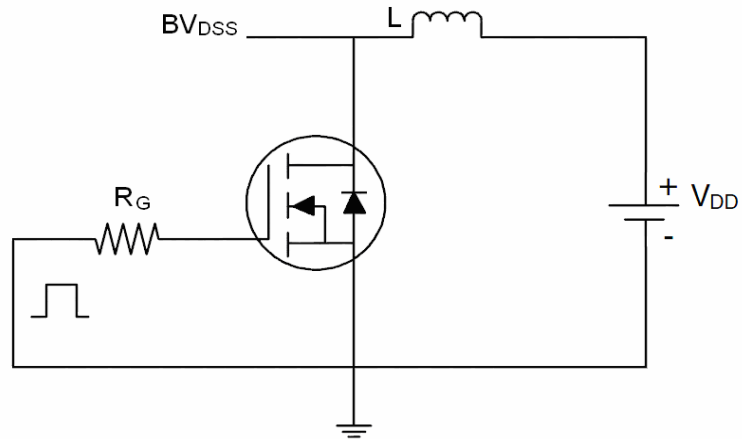

2) Gate Charge Test Circuit

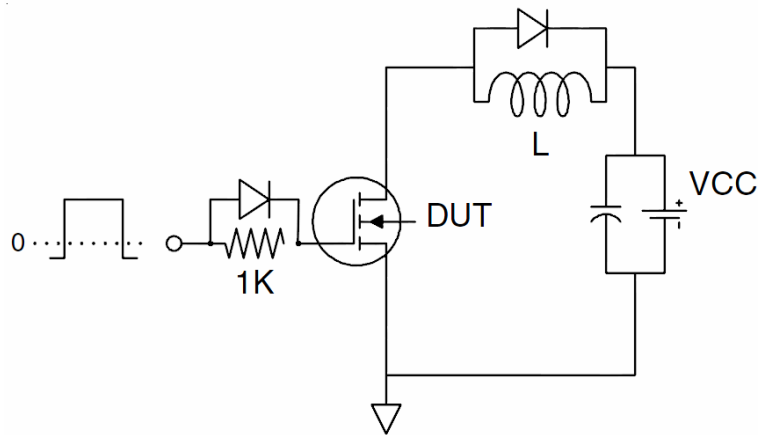

3) Switch Time Test Circuit

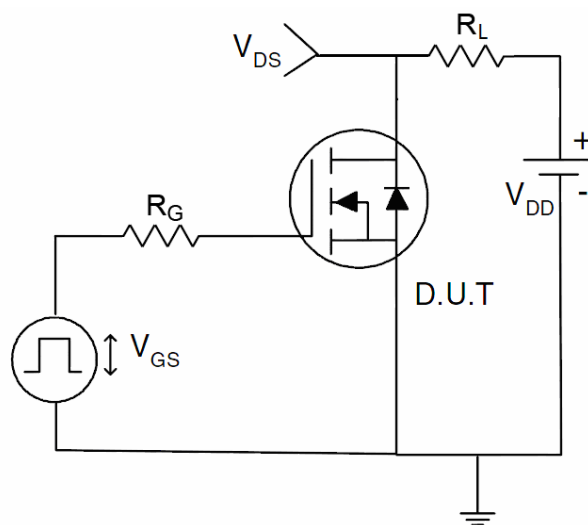

Typical Electrical and Thermal Characteristics (Curves)

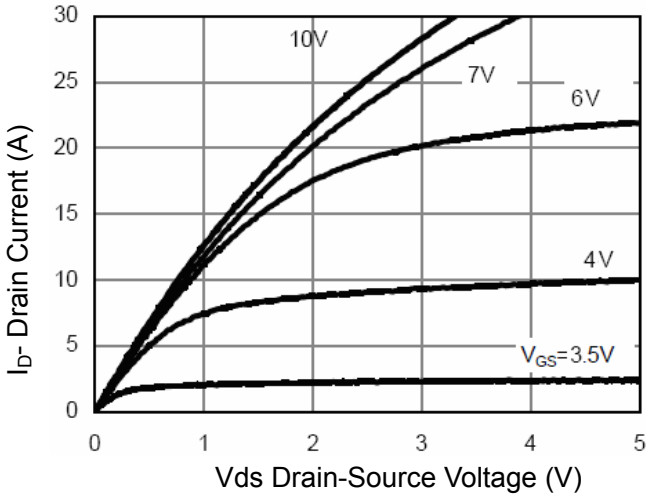

Figure 1 Output Characteristics

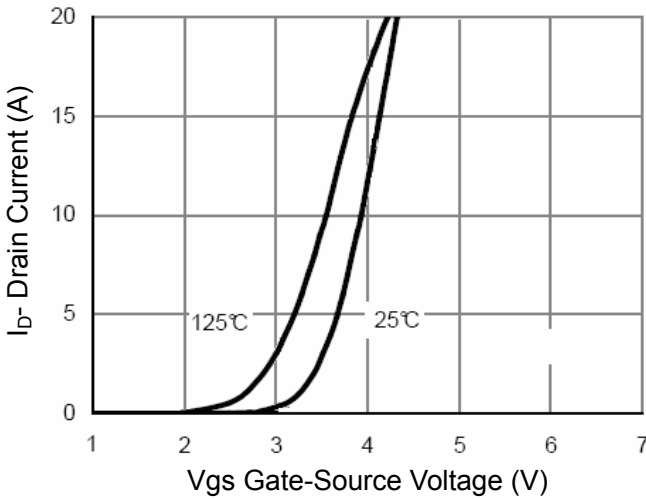

Figure 2 Transfer Characteristics

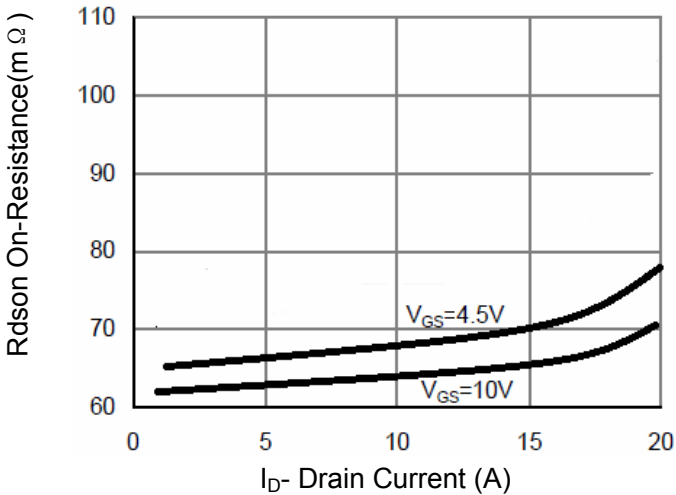

Figure 3 Rdson- Drain Current

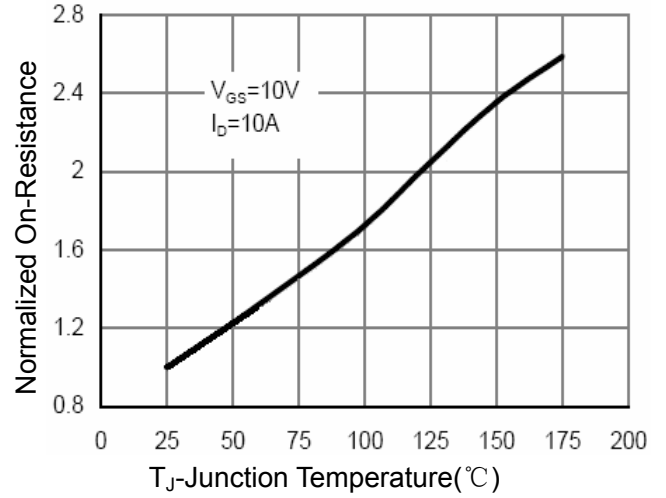

Figure 4 Rdson-Junction Temperature

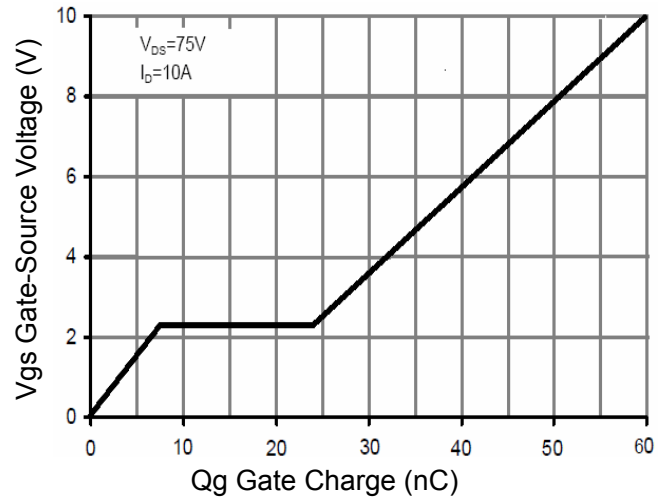

Figure 5 Gate Charge

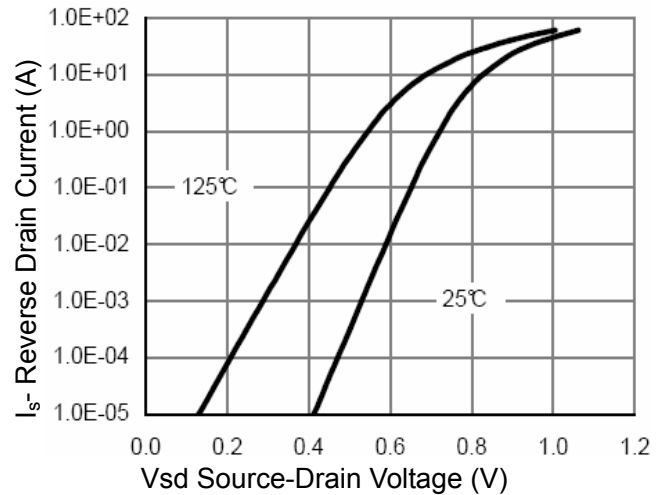

Figure 6 Source- Drain Diode Forward

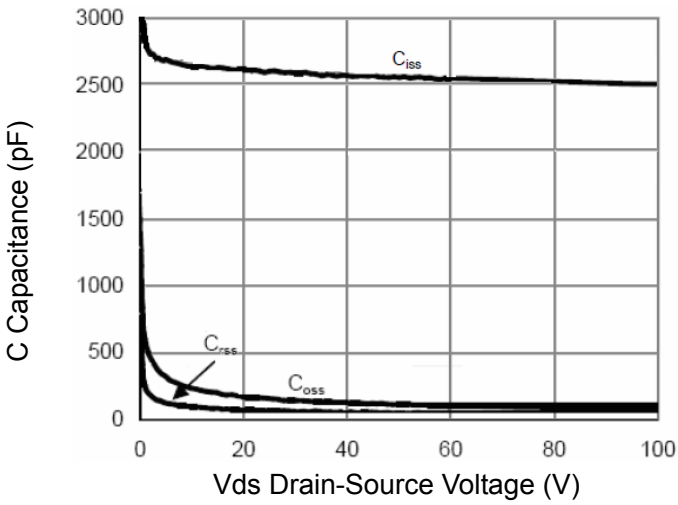

Figure 7 Capacitance vs Vds

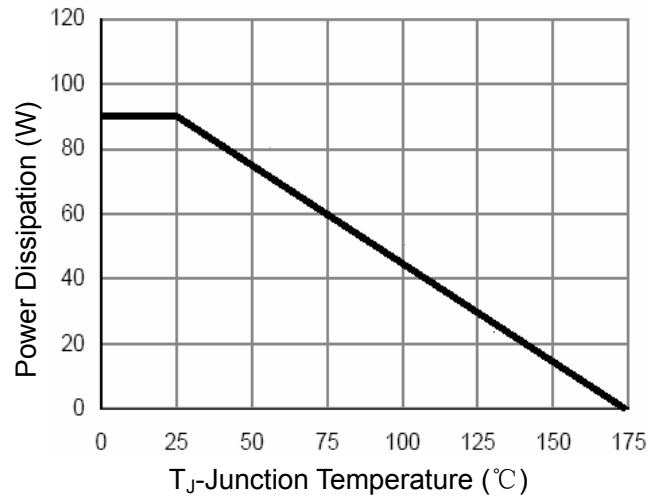

Figure 9 Power De-rating

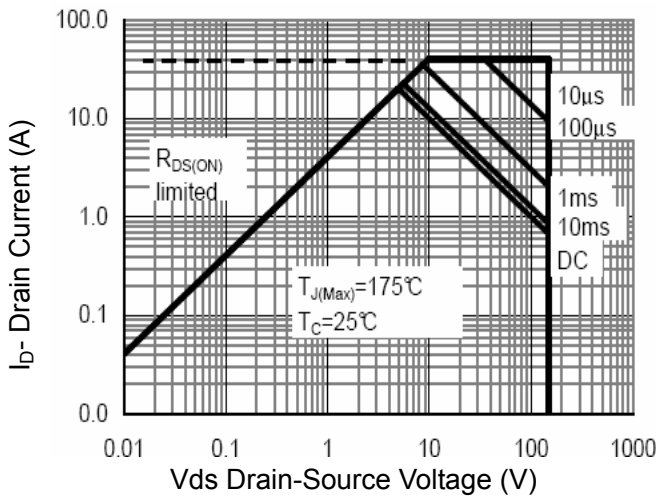

Figure 8 Safe Operation Area

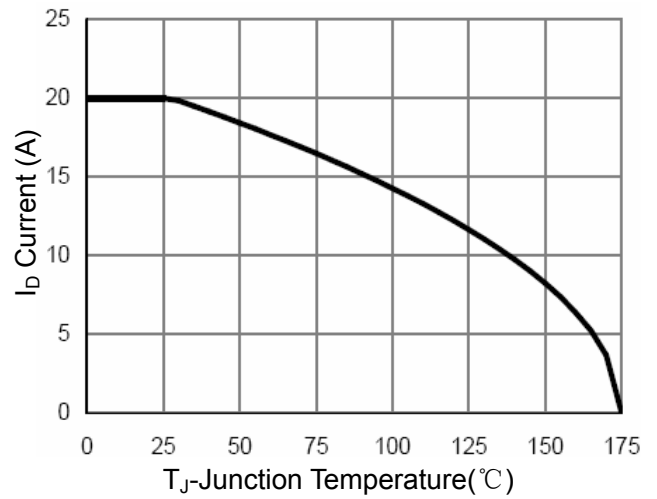

Figure 10 ID Current- Junction Temperature

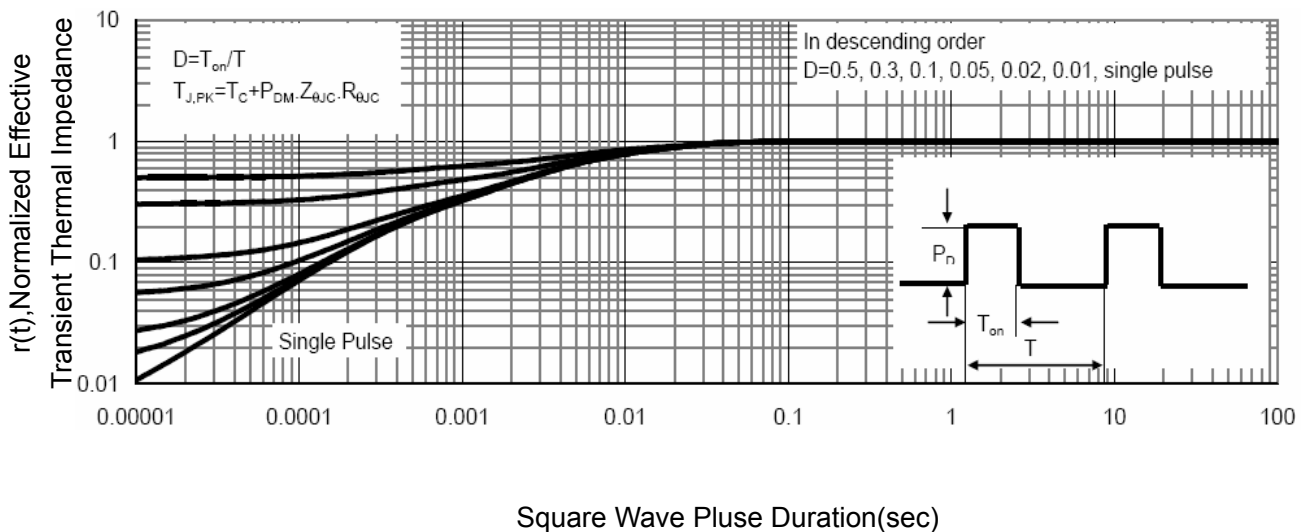
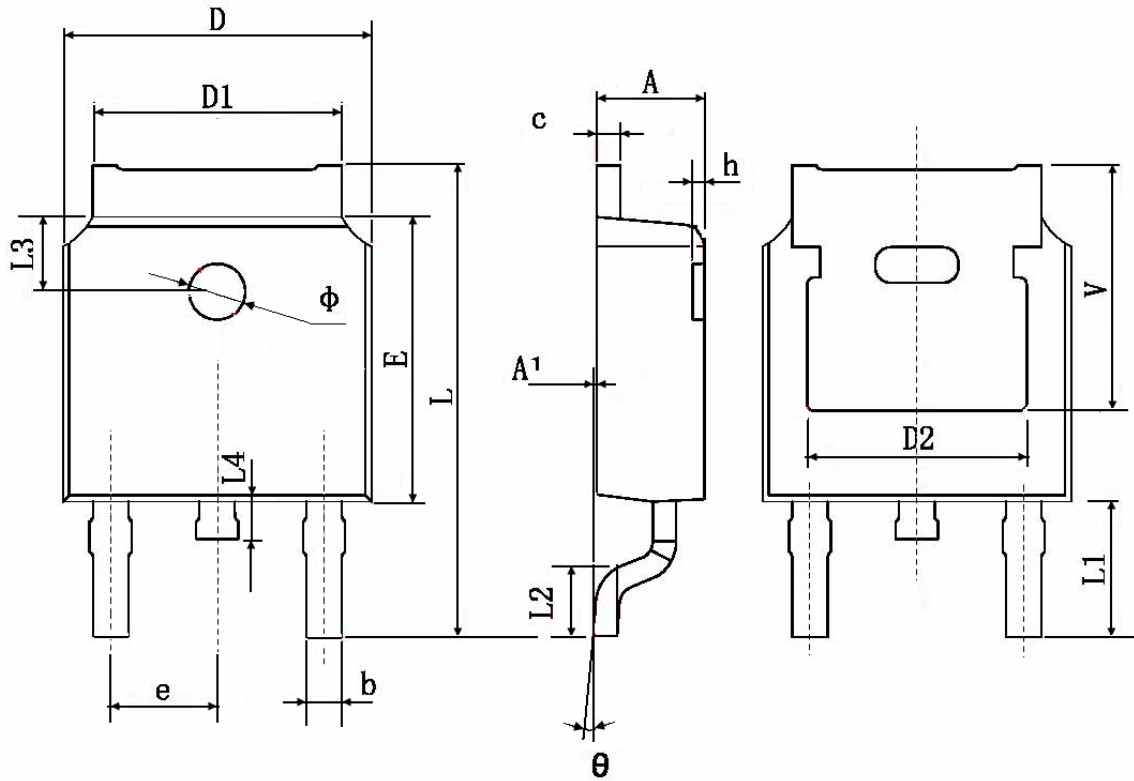

Figure 11 Normalized Maximum Transient Thermal Impedance

TO-252 Package Information



Symbol	Dimensions In Millimeters		Dimensions In Inches	
	Min.	Max.	Min.	Max.
A	2.200	2.400	0.087	0.094
A1	0.000	0.127	0.000	0.005
b	0.660	0.860	0.026	0.034
c	0.460	0.580	0.018	0.023
D	6.500	6.700	0.256	0.264
D1	5.100	5.460	0.201	0.215
D2	4.830 TYP.		0.190 TYP.	
E	6.000	6.200	0.236	0.244
e	2.186	2.386	0.086	0.094
L	9.800	10.400	0.386	0.409
L1	2.900 TYP.		0.114 TYP.	
L2	1.400	1.700	0.055	0.067
L3	1.600 TYP.		0.063 TYP.	
L4	0.600	1.000	0.024	0.039
phi	1.100	1.300	0.043	0.051
theta	0°	8°	0°	8°
h	0.000	0.300	0.000	0.012
V	5.350 TYP.		0.211 TYP.	

Attention

QIAOXIN assumes no responsibility for equipment failures that result from using products at values that exceed, even momentarily, rated values (such as maximum ratings, operating condition ranges, or other parameters) listed in products specifications of any and all QIAOXIN products described or contained herein. QIAOXIN products are not designed for use in life support appliances, devices or systems where malfunction of these products can be reasonably expected to result in personal injury. Reproduction in whole or in part is prohibited without the prior written consent of the copyright owner. QIAOXIN reserves the right to make changes to information published in this document, including without limitation specifications and product descriptions, at any time and without notice. This document supersedes and replaces all information supplied prior to the publication hereof.