

QIAOXIN N-Channel Super Trench Power MOSFET

Description

The VCRRP16N85AK uses **Super Trench** technology that is uniquely optimized to provide the most efficient high frequency switching performance. Both conduction and switching power losses are minimized due to an extremely low combination of $R_{DS(ON)}$ and Q_g . This device is ideal for high-frequency switching and synchronous rectification.

General Features

- $V_{DS} = 85V, I_D = 55A$
 $R_{DS(ON)} = 11.5m\Omega$ (typical) @ $V_{GS} = 10V$
 $R_{DS(ON)} = 15m\Omega$ (typical) @ $V_{GS} = 4.5V$
- Excellent gate charge x $R_{DS(on)}$ product(FOM)
- Very low on-resistance $R_{DS(on)}$
- 150 °C operating temperature
- Pb-free lead plating
- 100% UIS tested

Application

- DC/DC Converter
- Ideal for high-frequency switching and synchronous rectification

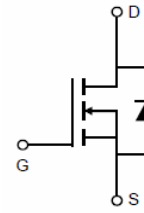

Schematic Diagram

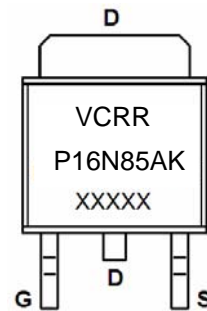

Marking and pin assignment

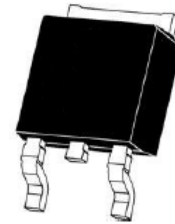

TO-252-2L top view

Package Marking and Ordering Information

Device Marking	Device	Device Package
VCRRP16N85AK		TO-252-2L

Absolute Maximum Ratings ($T_C = 25^\circ C$ unless otherwise noted)

Parameter	Symbol	Limit	Unit
Drain-Source Voltage	V_{DS}	85	V
Gate-Source Voltage	V_{GS}	± 20	V
Drain Current-Continuous	I_D	55	A
Drain Current-Continuous($T_C = 100^\circ C$)	$I_D(100^\circ C)$	44	A
Pulsed Drain Current	I_{DM}	220	A
Maximum Power Dissipation	P_D	138	W
Derating factor		0.92	W/ $^\circ C$
Single pulse avalanche energy (Note 1)	E_{AS}	156	mJ
Operating Junction and Storage Temperature Range	T_J, T_{STG}	-55 To 175	$^\circ C$

Thermal Characteristic

Thermal Resistance, Junction-to-Case	$R_{\theta JC}$	1.09	$^{\circ}C/W$
--------------------------------------	-----------------	------	---------------

Electrical Characteristics ($T_C=25^{\circ}C$ unless otherwise noted)

Parameter	Symbol	Condition	Min	Typ	Max	Unit
Off Characteristics						
Drain-Source Breakdown Voltage	BV_{DSS}	$V_{GS}=0V, I_D=250\mu A$	85		-	V
Zero Gate Voltage Drain Current	I_{DSS}	$V_{DS}=85V, V_{GS}=0V$	-	-	1	μA
Gate-Body Leakage Current	I_{GSS}	$V_{GS}=\pm 20V, V_{DS}=0V$	-	-	± 100	nA
On Characteristics						
Gate Threshold Voltage	$V_{GS(th)}$	$V_{DS}=V_{GS}, I_D=250\mu A$	1.2	1.7	2.5	V
Drain-Source On-State Resistance	$R_{DS(on)}$	$V_{GS}=10V, I_D=27.5A$	-	11.5	16	m Ω
		$V_{GS}=4.5V, I_D=27.5A$	-	15	24	m Ω
Forward Transconductance	g_{FS}	$V_{DS}=5V, I_D=27.5A$	-	35	-	S
Dynamic Characteristics						
Input Capacitance	C_{iss}	$V_{DS}=40V, V_{GS}=0V,$ $F=1.0MHz$	-	1600	-	PF
Output Capacitance	C_{oss}		-	250	-	PF
Reverse Transfer Capacitance	C_{rss}		-	20	-	PF
Switching Characteristics (Note 2)						
Turn-on Delay Time	$t_{d(on)}$	$V_{DD}=40V, I_D=27.5A$ $V_{GS}=10V, R_G=1.6\Omega$	-	9	-	nS
Turn-on Rise Time	t_r		-	5	-	nS
Turn-Off Delay Time	$t_{d(off)}$		-	22	-	nS
Turn-Off Fall Time	t_f		-	4	-	nS
Total Gate Charge	Q_g	$V_{DS}=40V, I_D=27.5A,$ $V_{GS}=10V$	-	31	-	nC
Gate-Source Charge	Q_{gs}		-	4.8	-	nC
Gate-Drain Charge	Q_{gd}		-	8.0	-	nC
Drain-Source Diode Characteristics						
Diode Forward Voltage	V_{SD}	$V_{GS}=0V, I_S=55A$	-		1.2	V
Diode Forward Current	I_S		-	-	55	A
Reverse Recovery Time	t_{rr}	$T_J = 25^{\circ}C, I_F = 55A$ $di/dt = 500A/\mu s$ (Note3)	-		26	nS
Reverse Recovery Charge	Q_{rr}		-		98	nC

Notes:

1. EAS condition : $T_J=25^{\circ}C, V_{DD}=40V, V_G=10V, L=0.5mH, R_G=25\Omega$
2. Guaranteed by design, not subject to production.
3. These curves are based on the junction-to-case thermal impedance which is measured with the device mounted to a large heat sin k, assuming a maximum junction temperature of $T_J(MAX)=175^{\circ}C$. The SOA curve provides a single pulse rating.

Typical Electrical and Thermal Characteristics

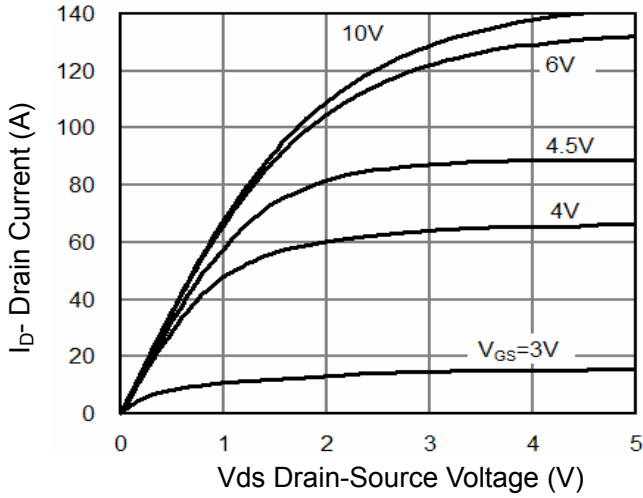

Figure 1 Output Characteristics

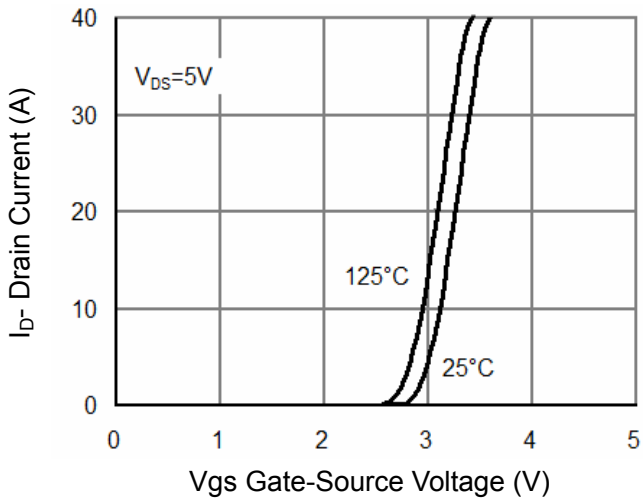

Figure 2 Transfer Characteristics

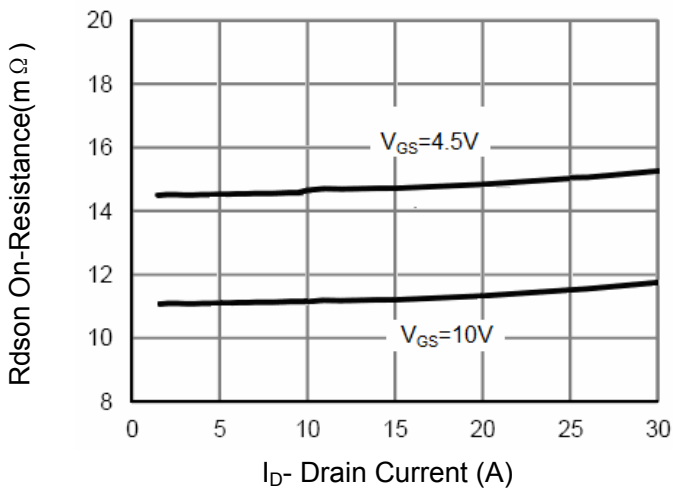

Figure 3 Rdson- Drain Current

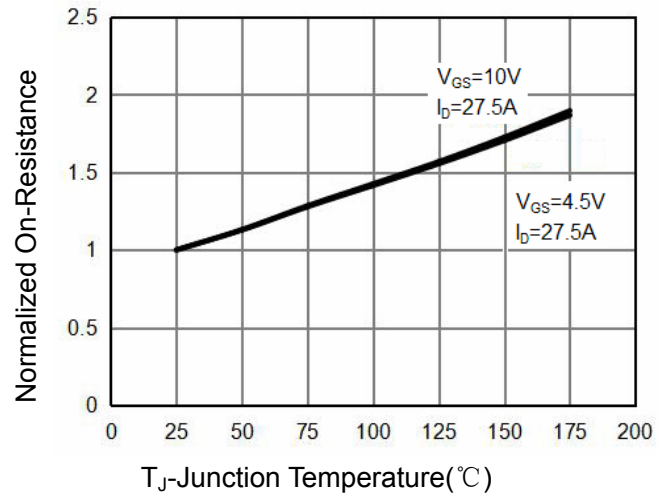

Figure 4 Rdson-Junction Temperature

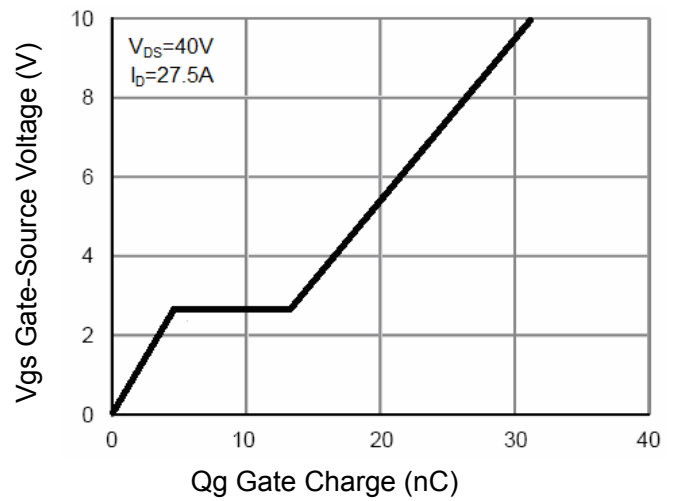

Figure 5 Gate Charge

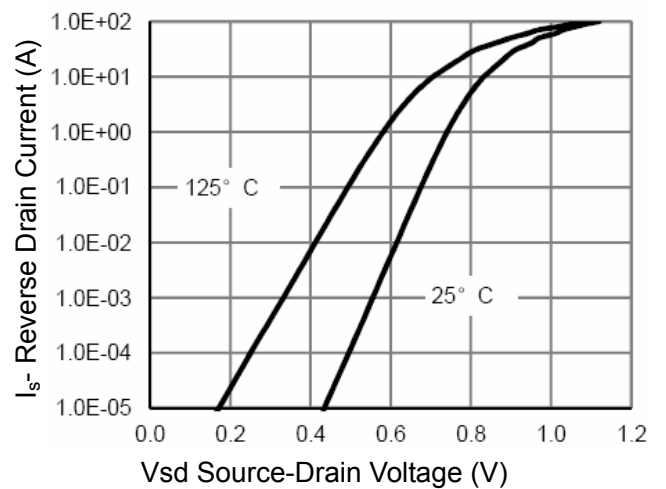
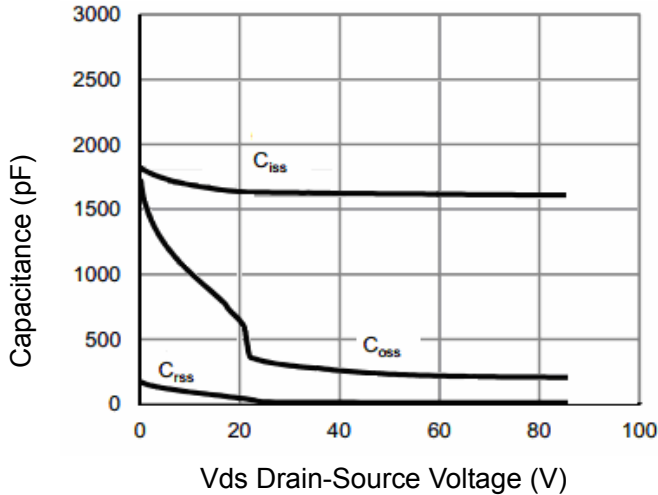
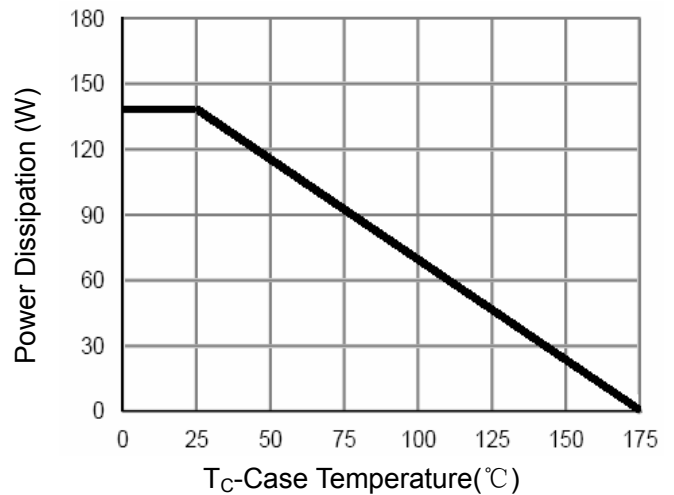

Figure 6 Source- Drain Diode Forward



Vds Drain-Source Voltage (V)
Figure 7 Capacitance vs Vds



Tc-Case Temperature(°C)
Figure 9 Power De-rating

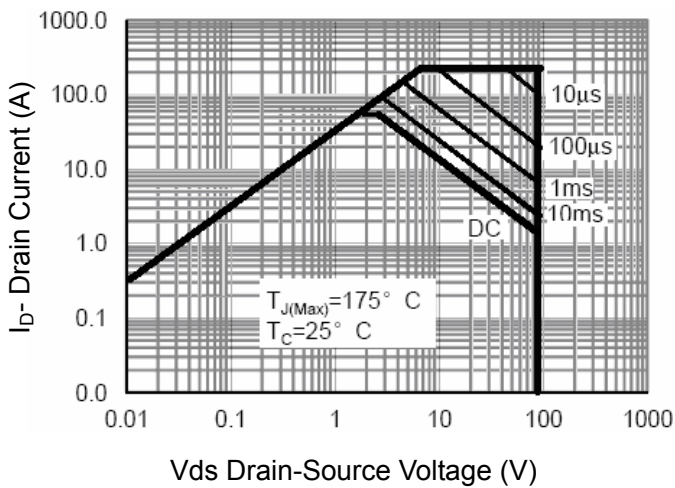

Vds Drain-Source Voltage (V)
Figure 8 Safe Operation Area (Note 3)

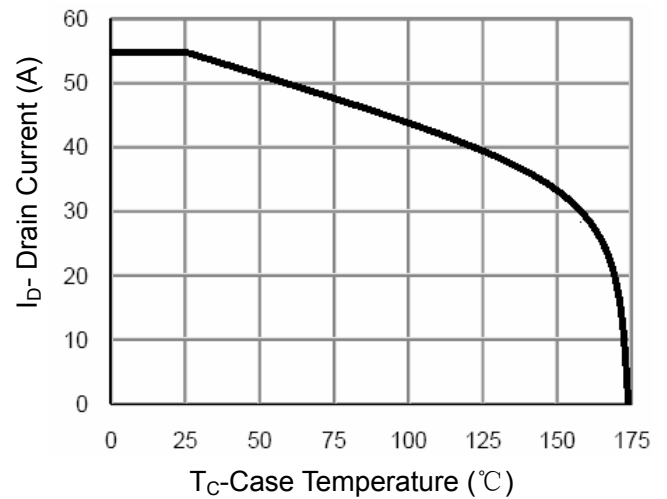

Tc-Case Temperature (°C)
Figure 10 Current De-rating

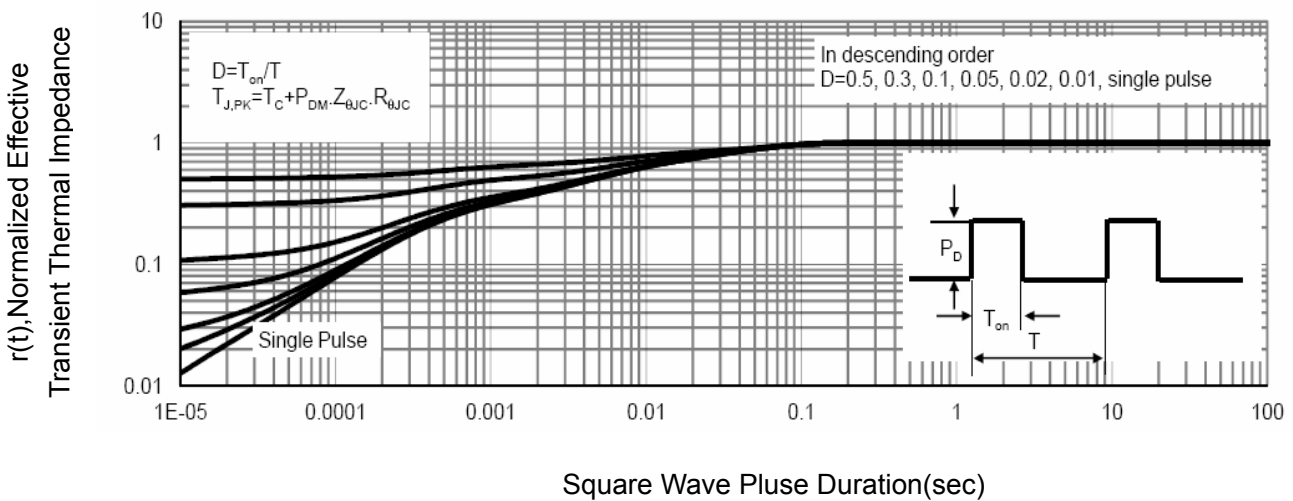

Square Wave Pulse Duration(sec)
Figure 11 Normalized Maximum Transient Thermal Impedance

TO-252-2L Package Information

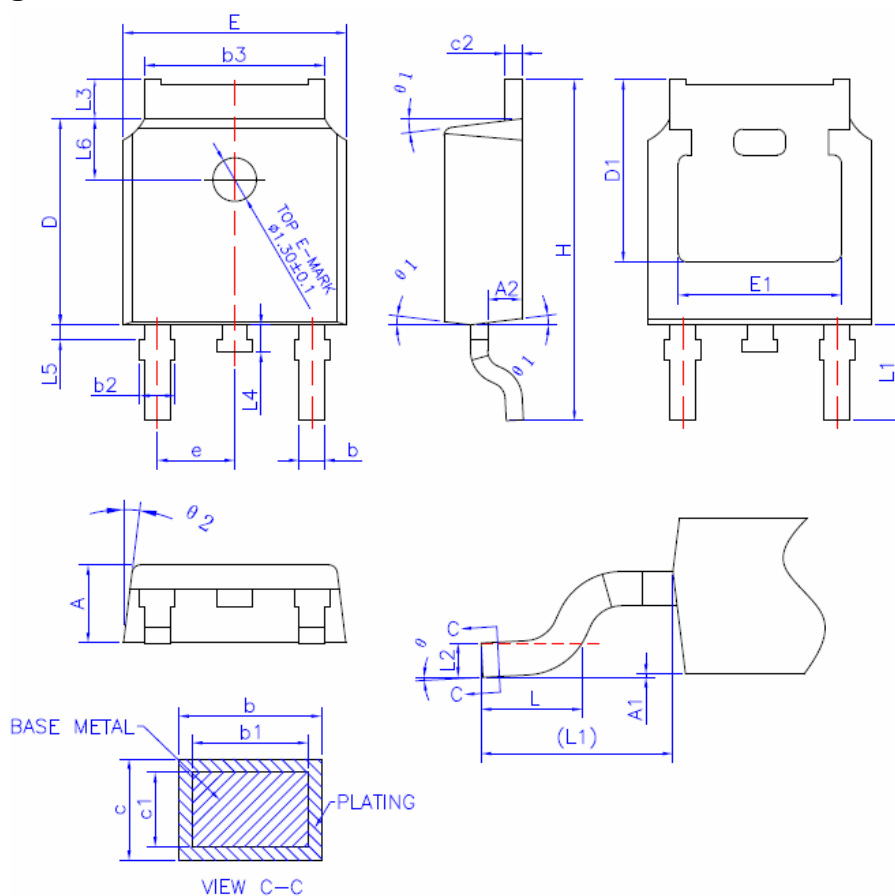

COMMON DIMENSIONS
(UNITS OF MEASURE =MILLIMETER)

SYMBOL	MIN	NOM	MAX
A	2.20	2.30	2.38
A1	0	—	0.10
A2	0.90	1.01	1.10
b	0.72	—	0.85
b1	0.71	0.76	0.81
b2	0.72	—	0.90
b3	5.13	5.33	5.46
c	0.47	—	0.60
c1	0.46	0.51	0.56
c2	0.47	—	0.60
D	6.00	6.10	6.20
D1	5.25	—	—
E	6.50	6.60	6.70
E1	4.70	—	—
e	2.186	2.286	2.386
H	9.80	10.10	10.40
L	1.40	1.50	1.70
L1	2.90 REF		
L2	0.508 BSC		
L3	0.90	—	1.25
L4	0.60	0.80	1.00
L5	0.15	—	0.75
L6	1.80 REF		
θ	0°	—	8°
θ_1	5°	7°	9°
θ_2	5°	7°	9°

NOTES:
ALL DIMENSIONS REFER TO JEDEC STANDARD
TO-252 AA DO NOT INCLUDE MOLD FLASH OR
PROTRUSIONS

Attention

QIAOXIN assumes no responsibility for equipment failures that result from using products at values that exceed, even momentarily, rated values (such as maximum ratings, operating condition ranges, or other parameters) listed in products specifications of any and all QIAOXIN products described or contained herein. QIAOXIN products are not designed for use in life support appliances, devices or systems where malfunction of these products can be reasonably expected to result in personal injury. Reproduction in whole or in part is prohibited without the prior written consent of the copyright owner. QIAOXIN reserves the right to make changes to information published in this document, including without limitation specifications and product descriptions, at any time and without notice. This document supersedes and replaces all information supplied prior to the publication hereof.