

## Surface Mount 2-Electrode Gas Discharge Tube (GDT)

### QX1206 Series

#### Description

Gas discharge Tubes (GDT) are classical components for protecting the installations of the telecommunications. It is essential that IT and telecommunications systems -with their high-grade but sensitive electronic circuits - be protected by arresters.

The 1206 series GDT offers high surge ratings in a miniature package. It's designed for surface mounting on PCB with small size 3.2x1.6x1.6mm. Low insertion loss is perfectly suited to broadband equipment applications. The capacitance does not vary with voltage, and will not cause operational problems with ADSL2+, where capacitance variation across Tip and Ring is undesirable. These devices are extremely robust and are able to divert a 500A pulse in a miniature package 1206 without destruction.

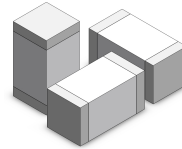

#### Schematic Symbol

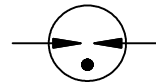

#### Features

- u Non-Radioactive
- u RoHS compliant
- u Ultra low capacitance (<0.5pF)
- u UL recognized
- u Excellent response to fast rising transients
- u 0.5KA surge capability tested with 8/20μs pulse as defined by IEC 61000-4-5
- u Square Outline

#### Applications

- u Communication equipment
- u CATV equipment
- u Test equipment
- u Data lines
- u Power supplies
- u Telecom SLIC protection
- u Broadband equipment
- u ADSL equipment, including ADSL2+
- u XDSL equipment
- u Satellite and CATV equipment
- u General telecom equipment
- u ESD protection

#### Agency Approvals

AGENCY	AGENCY FILE NUMBER
	E466847

#### Product Characteristics

<b>Materials</b>	Dull Tin-plated
<b>Product Marking</b>	Without
<b>Storage and Operational Temperature</b>	-40 to +90°C
<b>Weight</b>	~30mg

## Surface Mount 2-Electrode Gas Discharge Tube (GDT)

### QX1206 Series

#### Device Dimensions (Unit: mm)

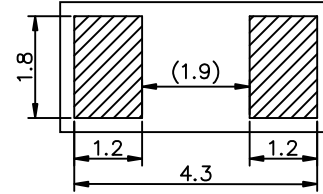
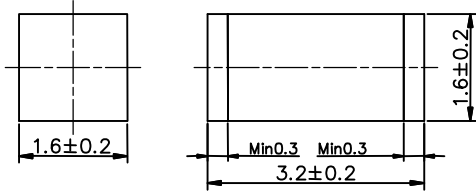

Recommended pad outline

#### Electrical Characteristics

Part Number	DC Spark-over Voltage	Maximum Impulse Spark-over Voltage		Minimum Insulation Resistance	Maximum Capacitance	Arc Voltage	Nominal Impulse Discharge Current	Impulse Discharge Voltage
	@100V/S	@100V/μs	1KV/μs		@1MHz	@1A	@8/20μs ±5 times	@10/700μs
QX1206-150ASMD	150V±30%	600V	700V	1 GΩ (at 50V DC)	0.5pF	~15V	0.5KA	4KV
QX1206-200ASMD	200V±30%	600V	750V	1 GΩ (at 100V DC)	0.5pF	~15V	0.5KA	4KV
QX1206-230ASMD	230V±30%	700V	800V	1 GΩ (at 100V DC)	0.5pF	~15V	0.5KA	4KV
QX1206-300ASMD	300V±30%	750V	850V	1 GΩ (at 100V DC)	0.5pF	~15V	0.5KA	4KV
QX1206-350ASMD	350V±30%	800V	900V	1 GΩ (at 100V DC)	0.5pF	~15V	0.5KA	4KV
QX1206-400ASMD	400V±30%	950V	1050V	1 GΩ (at 100V DC)	0.5pF	~15V	0.5KA	4KV
QX1206-420ASMD	420V±30%	950V	1050V	1 GΩ (at 100V DC)	0.5pF	~15V	0.5KA	4KV
QX1206-470ASMD	470V±30%	1100V	1200V	1 GΩ (at 100V DC)	0.5pF	~15V	0.5KA	4KV

**Notes:**

- 1). Terms in accordance with ITU-T K.12 and GB/T 9043-2008
- 2). At delivery AQL 0.65 level II, DIN ISO 2859

## Surface Mount 2-Electrode Gas Discharge Tube (GDT)

### QX1206 Series

#### Electrical Rating

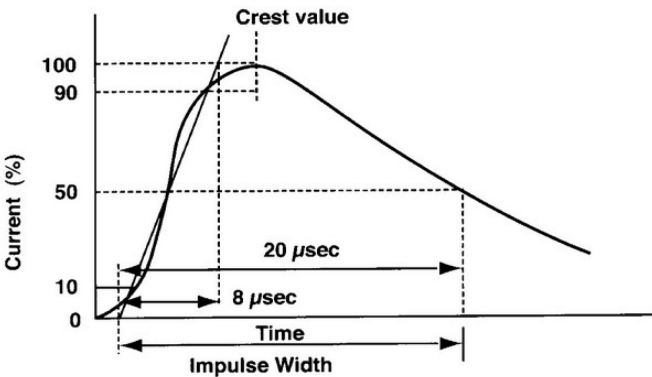
Item	Test Condition / Description	Requirement
<b>DC Spark-over Voltage</b>	The voltage is measured with a slowly rate of rise $dv / dt=100V/s$	To meet the specified value
<b>Impulse Spark-over Voltage</b>	The maximum impulse spark-over voltage is measured with a rise time of $dv / dt=100V/\mu s$ or $1KV/\mu s$	
<b>Insulation Resistance</b>	The resistance of gas tube shall be measured each terminal each other terminal, please see above spec.	
<b>Capacitance</b>	The capacitance of gas tube shall be measured each terminal to each other terminal. Test frequency :1MHz	
<b>Nominal Impulse Discharge Current</b>	The maximum current applying a waveform of 8/20 $\mu s$ that can be applied across the terminals of the gas tube. One hour after the test is completed, re-testing of the DC spark-over voltage does not exceed $\pm 40\%$ of the nominal DC spark-over voltage. Dwell time between pulses is 3 minutes. 	

#### Recommended soldering profile

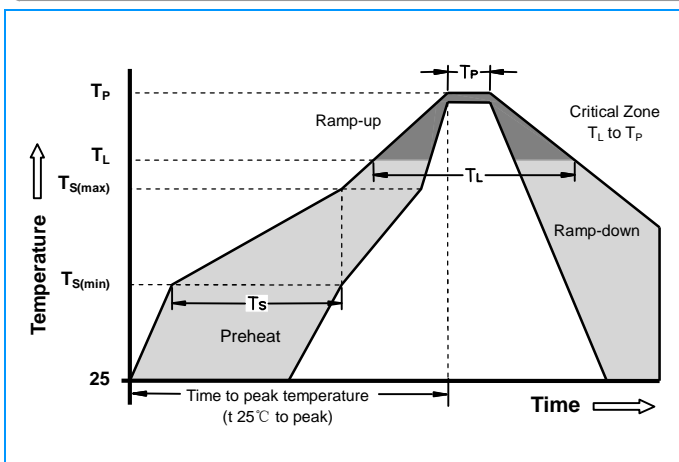

<b>Reflow Condition</b>		Pb - Free assembly
<b>Pre Heat</b>	- Temperature Min ( $T_{s(min)}$ )	150°C
	- Temperature Max ( $T_{s(max)}$ )	200°C
	- Time (min to max) ( $t_s$ )	60 -180 Seconds
<b>Average ramp up rate ( Liquidus Temp <math>T_L</math>) to peak</b>		3°C/second max
<b><math>T_{s(max)}</math> to <math>T_L</math> - Ramp-up Rate</b>		5°C/second max
<b>Reflow</b>	- Temperature ( $T_L$ ) (Liquidus)	217°C
	- Time (min to max) ( $t_s$ )	60 -150 Seconds
<b>Peak Temperature (<math>T_P</math>)</b>		260 +0/-5°C
<b>Time within 5°C of actual peak Temperature (<math>t_p</math>)</b>		10 - 30 Seconds
<b>Ramp-down Rate</b>		6°C/second max
<b>Time 25°C to peak Temperature (<math>T_P</math>)</b>		8 minutes Max
<b>Do not exceed</b>		260°C

## Surface Mount 2-Electrode Gas Discharge Tube (GDT)

**QX1206**

### Part Numbering

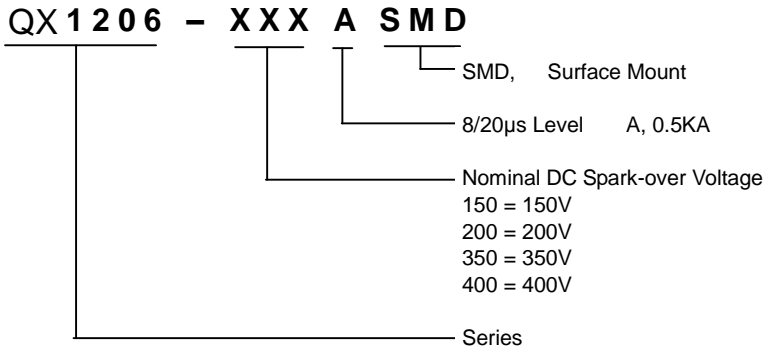

### Tape and Reel Dimensions

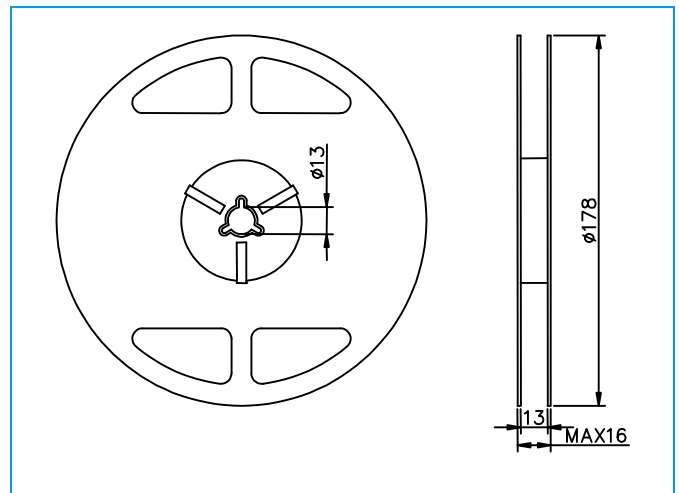
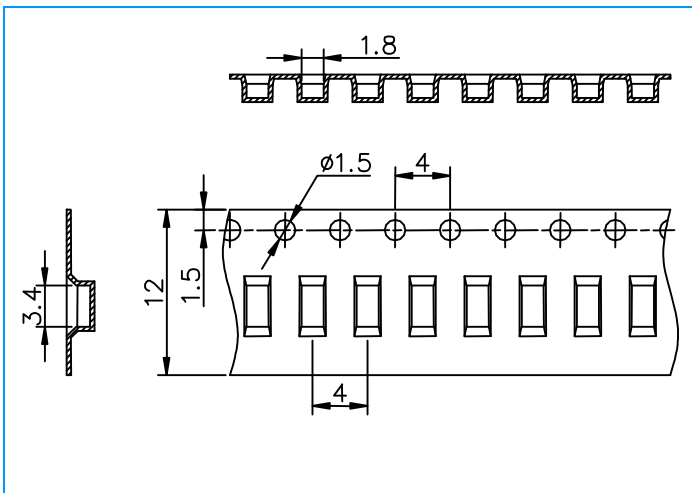

### Packaging

Part Number	Description	Quantity
QX1206-XXXASMD	12mm Tape & 7" Reel	2500

### Cautions and warnings

- Gas discharge tubes (GDT) must not be operated directly in power supply networks.
- Gas discharge tubes (GDT) may become hot in case of longer periods of current stress (danger of burning).
- Gas discharge tubes (GDT) may be used only within their specified values. In the event of overload, the head contacts may fail or the component may be destroyed.
- Damaged Gas discharge tubes (GDT) must not be re-used.