

## QIAOXIN N-Channel Super Junction Power MOSFET III

### General Description

The series of devices use advanced trench gate super junction technology and design to provide excellent  $R_{DS(ON)}$  with low gate charge. This super junction MOSFET fits the industry's AC-DC SMPS requirements for PFC, AC/DC power conversion, and industrial power applications.

### Features

- New technology for high voltage device
- Low on-resistance and low conduction losses
- Small package
- Ultra Low Gate Charge cause lower driving requirements
- 100% Avalanche Tested
- ROHS compliant

### Application

- Power factor correction (PFC)
- Switched mode power supplies(SMPS)
- Uninterruptible Power Supply (UPS)

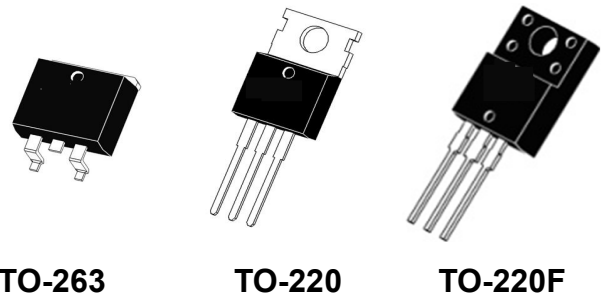
$V_{DS}$	700	V
$R_{DS(ON)TYP}$	680	m $\Omega$
$I_D$	7	A



Schematic diagram

### Package Marking And Ordering Information

Device	Device Package	Marking
VCRR 70T680D	TO-263	VCRR 70T680D
VCRR 70T680	TO-220	VCRR 70T680
VCRR 70T680F	TO-220F	VCRR 70T680F



TO-263

TO-220

TO-220F

Table 1. Absolute Maximum Ratings ( $T_c=25^\circ\text{C}$ )

Parameter	Symbol	VCRR70T680D VCRR70T680	VCRR70T680F	Unit
Drain-Source Voltage ( $V_{GS}=0V$ )	$V_{DS}$	700		V
Gate-Source Voltage ( $V_{DS}=0V$ ) AC ( $f>1$ Hz)	$V_{GS}$	$\pm 30$		V
Continuous Drain Current at $T_c=25^\circ\text{C}$	$I_{D(DC)}$	7	7*	A
Continuous Drain Current at $T_c=100^\circ\text{C}$	$I_{D(DC)}$	4.5	4.5*	A
Pulsed drain current (Note 1)	$I_{DM(pluse)}$	28	28*	A
Maximum Power Dissipation( $T_c=25^\circ\text{C}$ )	$P_D$	60	31.4	W
Derate above $25^\circ\text{C}$		0.48	0.25	W/ $^\circ\text{C}$
Single pulse avalanche energy (Note 2)	$E_{AS}$	101		mJ
Avalanche current (Note 1)	$I_{AR}$	1.5		A
Repetitive Avalanche energy , $t_{AR}$ limited by $T_{jmax}$ (Note 1)	$E_{AR}$	0.28		mJ

Parameter	Symbol	VCRR70T680D VCRR70T680	VCRR70T680F	Unit
Drain Source voltage slope, $V_{DS} \leq 480V$ ,	dv/dt	50		V/ns
Reverse diode dv/dt, $V_{DS} \leq 480V, I_{SD} < I_D$	dv/dt	15		V/ns
Operating Junction and Storage Temperature Range	$T_J, T_{STG}$	-55...+150		°C

\* limited by maximum junction temperature

**Table 2. Thermal Characteristic**

Parameter	Symbol	VCRR70T680D VCRR70T680	VCRR70T680F	Unit
Thermal Resistance, Junction-to-Case (Maximum)	$R_{thJC}$	2.08	3.98	°C/W
Thermal Resistance, Junction-to-Ambient (Maximum)	$R_{thJA}$	62	80	°C/W

**Table 3. Electrical Characteristics (TA=25°C unless otherwise noted)**

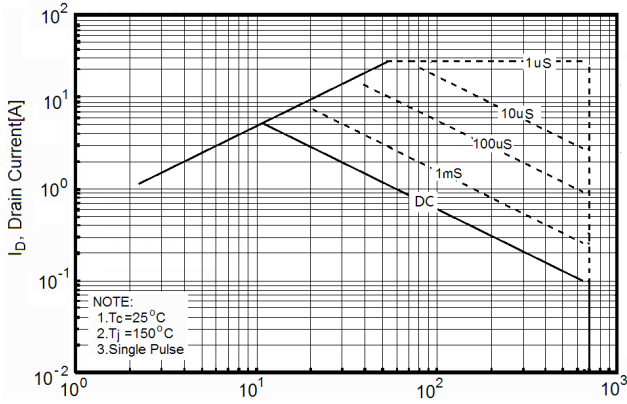
Parameter	Symbol	Condition	Min	Typ	Max	Unit
<b>On/off states</b>						
Drain-Source Breakdown Voltage	$BV_{DSS}$	$V_{GS}=0V, I_D=250\mu A$	700			V
Zero Gate Voltage Drain Current( $T_c=25^\circ C$ )	$I_{DSS}$	$V_{DS}=700V, V_{GS}=0V$			1	$\mu A$
Zero Gate Voltage Drain Current( $T_c=125^\circ C$ )	$I_{DSS}$	$V_{DS}=700V, V_{GS}=0V$			100	$\mu A$
Gate-Body Leakage Current	$I_{GSS}$	$V_{GS}=\pm 20V, V_{DS}=0V$			$\pm 100$	nA
Gate Threshold Voltage	$V_{GS(th)}$	$V_{DS}=V_{GS}, I_D=250\mu A$	3		4	V
Drain-Source On-State Resistance	$R_{DS(on)}$	$V_{GS}=10V, I_D=3.5A$		680	760	m $\Omega$
<b>Dynamic Characteristics</b>						
Input Capacitance	$C_{iss}$	$V_{DS}=50V, V_{GS}=0V,$ $F=1.0MHz$		435		pF
Output Capacitance	$C_{oss}$			28		pF
Reverse Transfer Capacitance	$C_{rss}$			3.3		pF
Total Gate Charge	$Q_g$	$V_{DS}=480V, I_D=7A,$ $V_{GS}=10V$		11		nC
Gate-Source Charge	$Q_{gs}$			3.5		nC
Gate-Drain Charge	$Q_{gd}$			5		nC
<b>Switching times</b>						
Turn-on Delay Time	$t_{d(on)}$	$V_{DD}=420V, I_D=3.5A,$ $R_G=4.7\Omega, V_{GS}=10V$		8.5		nS
Turn-on Rise Time	$t_r$			7		nS
Turn-Off Delay Time	$t_{d(off)}$			59	77	nS
Turn-Off Fall Time	$t_f$			9.5	16	nS
<b>Source- Drain Diode Characteristics</b>						
Source-drain current(Body Diode)	$I_{SD}$	$T_c=25^\circ C$			7	A
Pulsed Source-drain current(Body Diode)	$I_{SDM}$				28	A
Forward On Voltage	$V_{SD}$	$T_j=25^\circ C, I_{SD}=7A, V_{GS}=0V$		0.9	1.2	V
Reverse Recovery Time	$t_{rr}$	$T_j=25^\circ C, I_F=3.5A, di/dt=100A/\mu s$		210		nS
Reverse Recovery Charge	$Q_{rr}$			0.85		$\mu C$
Peak Reverse Recovery Current	$I_{rrm}$			8		A

Notes 1.Repetitive Rating: Pulse width limited by maximum junction temperature

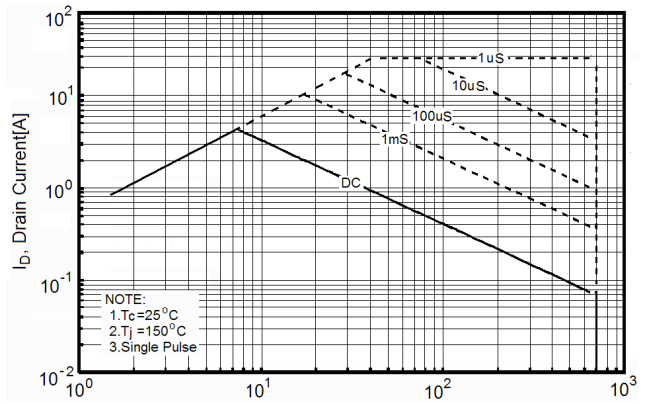
2.  $T_j=25^\circ C, V_{DD}=50V, V_G=10V, R_G=25\Omega$

**TYPICAL ELECTRICAL AND THERMAL CHARACTERISTICS (curves)**

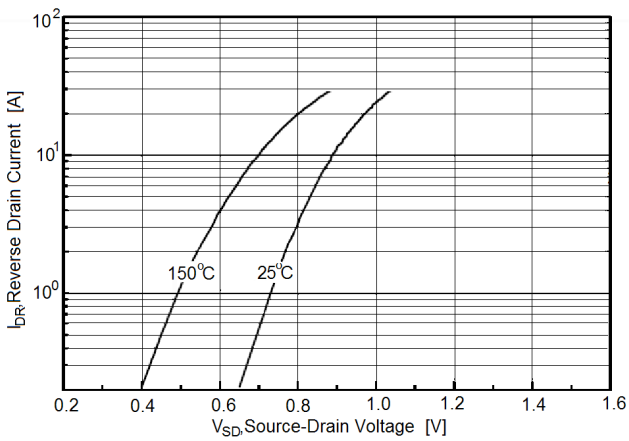
**Figure1. Safe operating area**



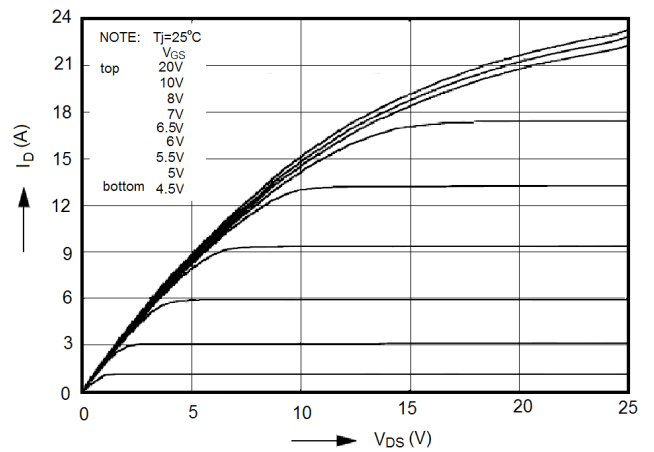
**Figure2. Safe operating area for TO-220F**



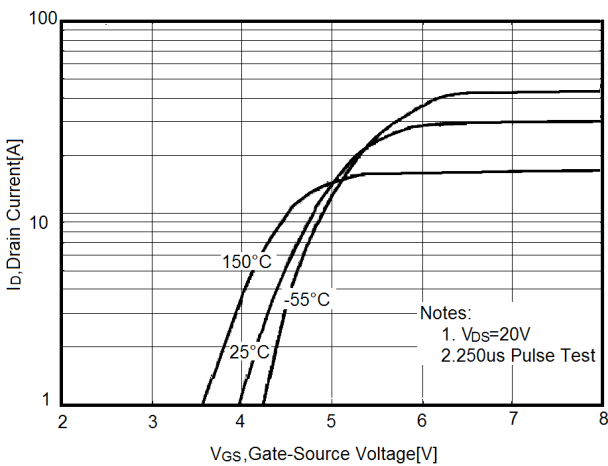
**Figure3. Source-Drain Diode Forward Voltage**



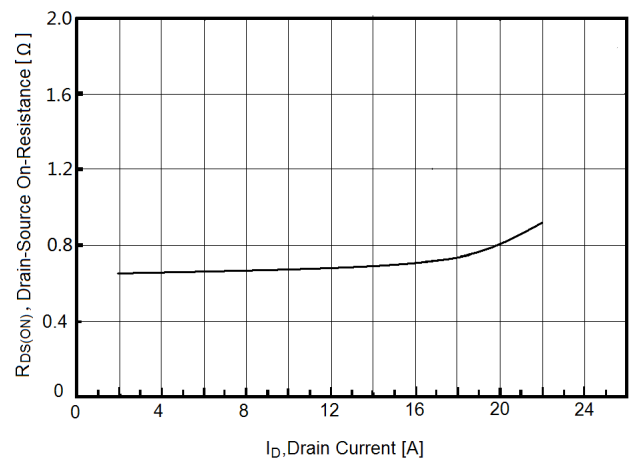
**Figure4. Output characteristics**



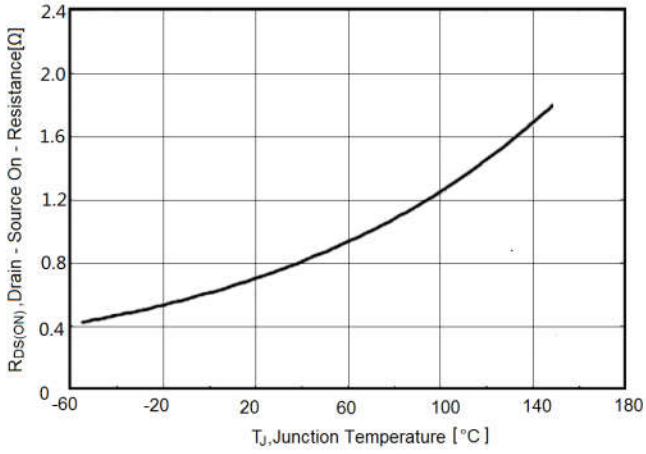
**Figure5. Transfer characteristics**



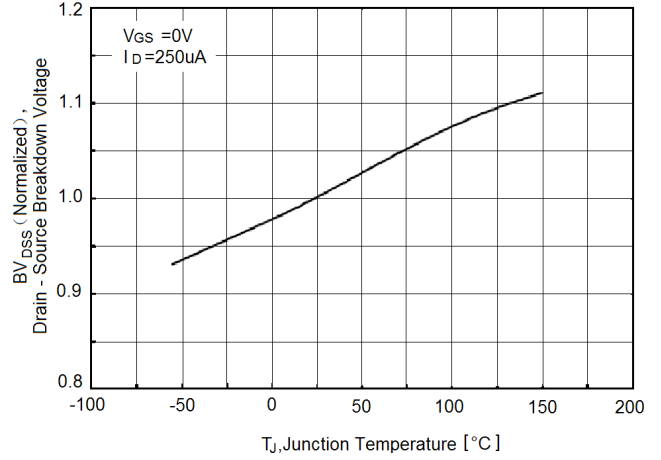
**Figure6. Static drain-source on resistance**



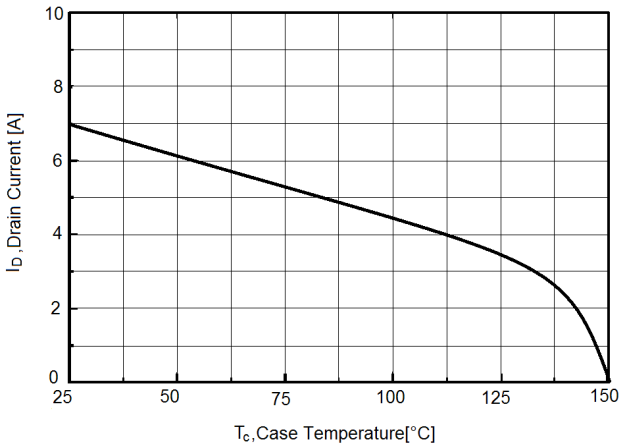
**Figure7.  $R_{DS(ON)}$  vs Junction Temperature**



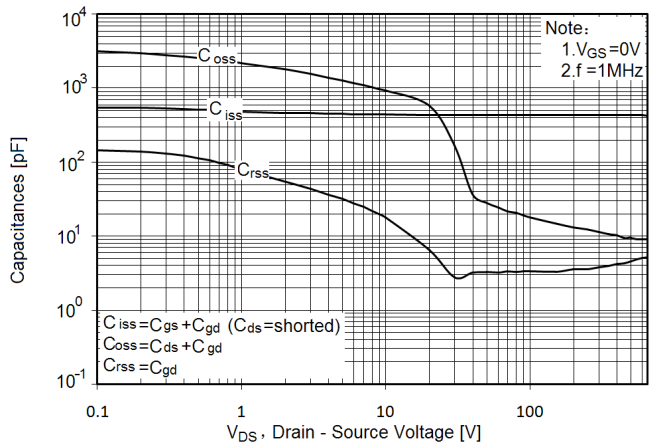
**Figure8.  $BV_{DSS}$  vs Junction Temperature**



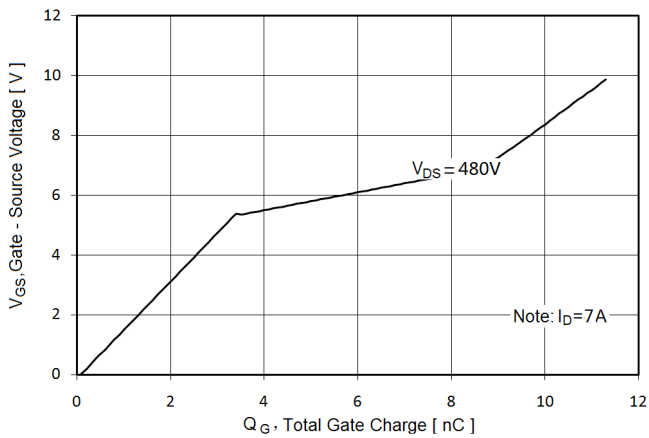
**Figure9. Maximum  $I_D$  vs Junction Temperature**



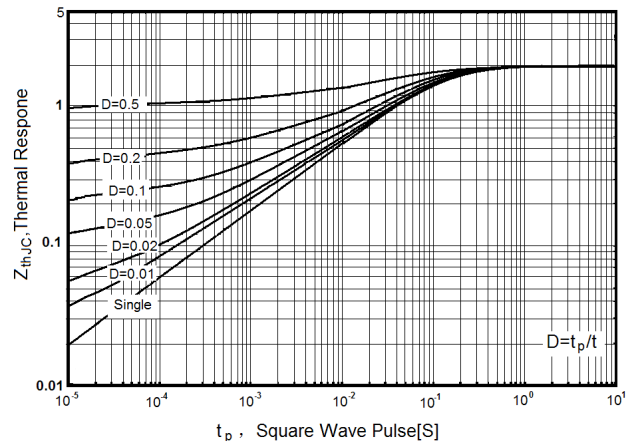
**Figure10. Capacitance**



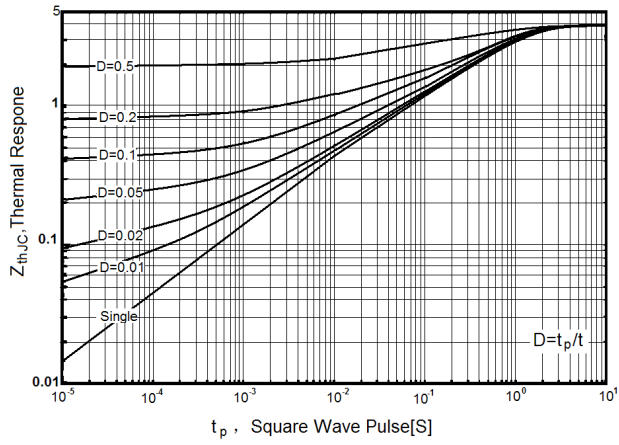
**Figure11. Gate charge waveforms**



**Figure12. Transient Thermal Impedance**

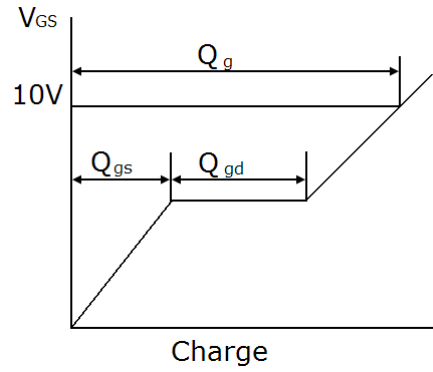
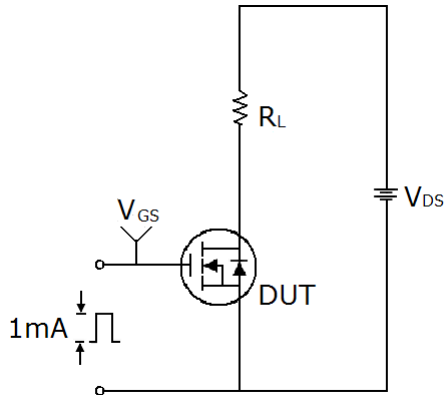


**Figure13. Transient Thermal Impedance for TO-220F**

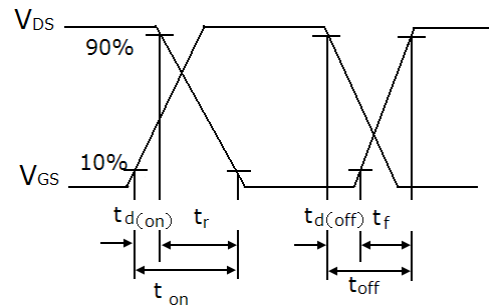
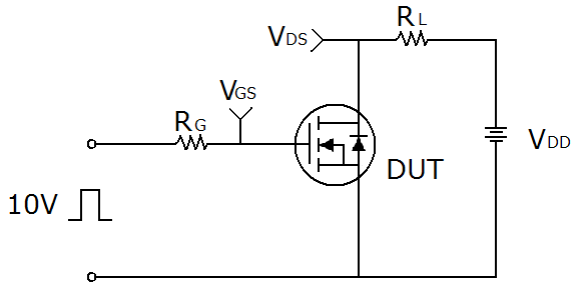


## Test circuit

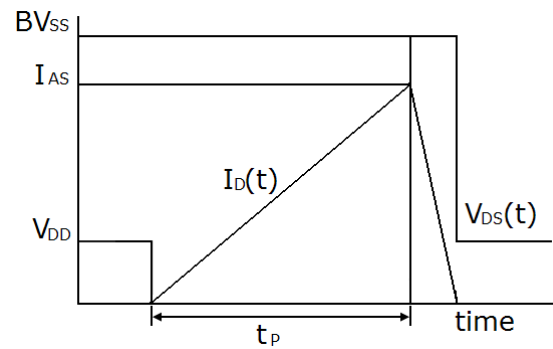
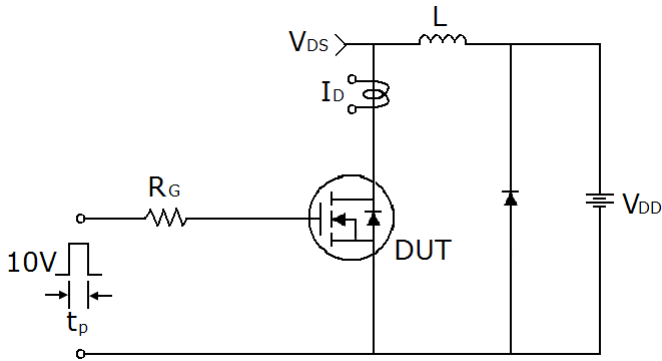
### 1) Gate charge test circuit & Waveform



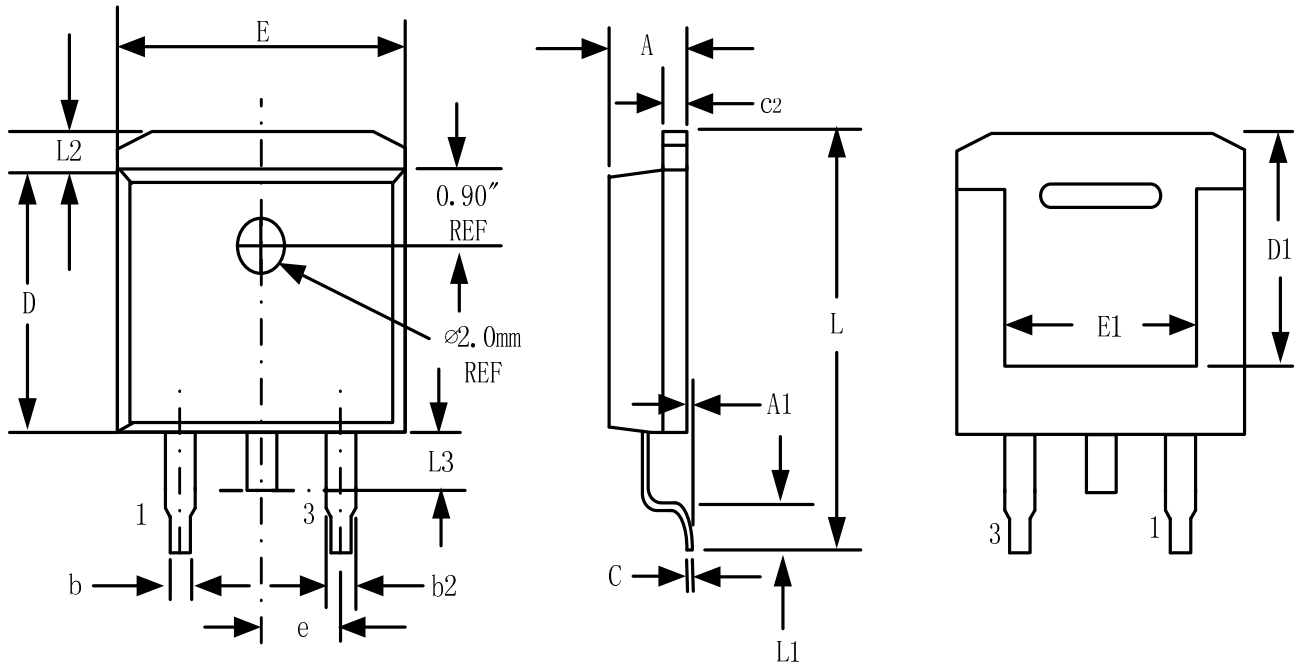
### 2) Switch Time Test Circuit:



### 3) Unclamped Inductive Switching Test Circuit & Waveforms

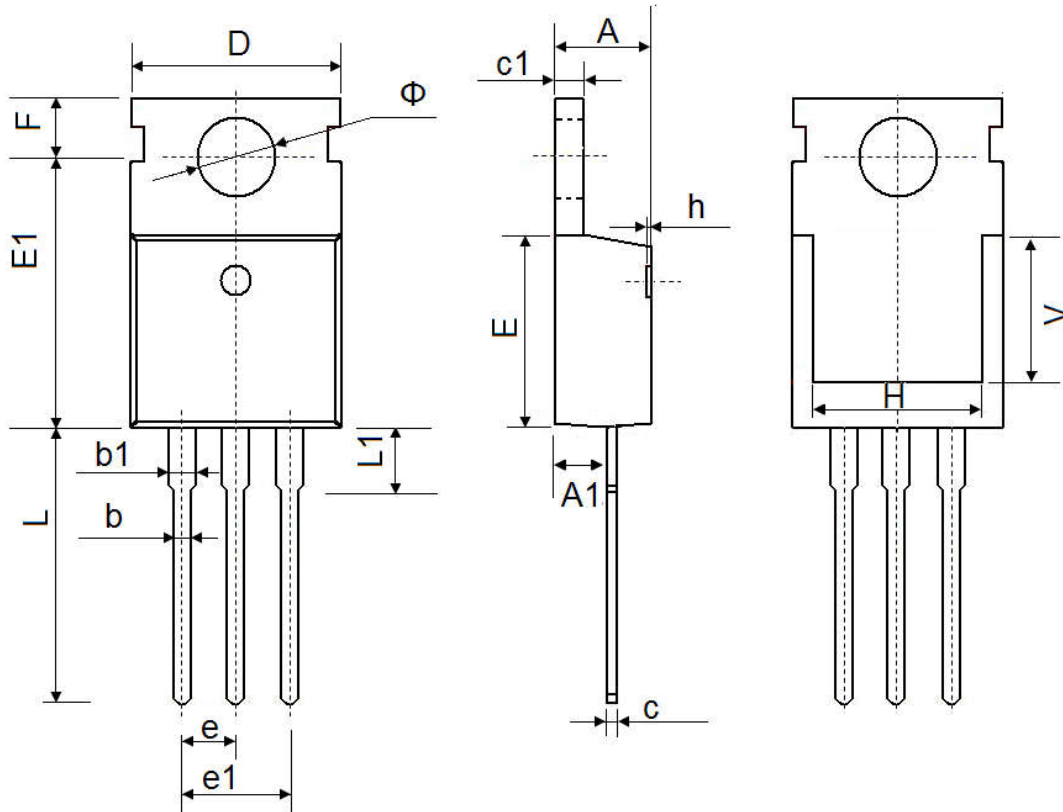


## TO-263-3L Package Information



Symbol	Dimensions In Millimeters		Dimensions In Inches	
	Min.	Max.	Min.	Max.
A	4.32	4.57	0.170	0.180
A1	-	0.25		0.010
b	0.71	0.94	0.028	0.037
b2	1.15	1.40	0.045	0.055
c	0.46	0.61	0.018	0.024
c2	1.22	1.40	0.048	0.055
D	8.89	9.40	0.350	0.370
D1	8.01	8.23	0.315	0.324
E	10.04	10.28	0.395	0.405
E1	7.88	8.08	0.310	0.318
e	2.54 BSC		0.100 BSC	
L	14.73	15.75	0.580	0.620
L1	2.29	2.79	0.090	0.110
L2	1.15	1.39	0.045	0.055
L3	1.27	1.77	0.050	0.070

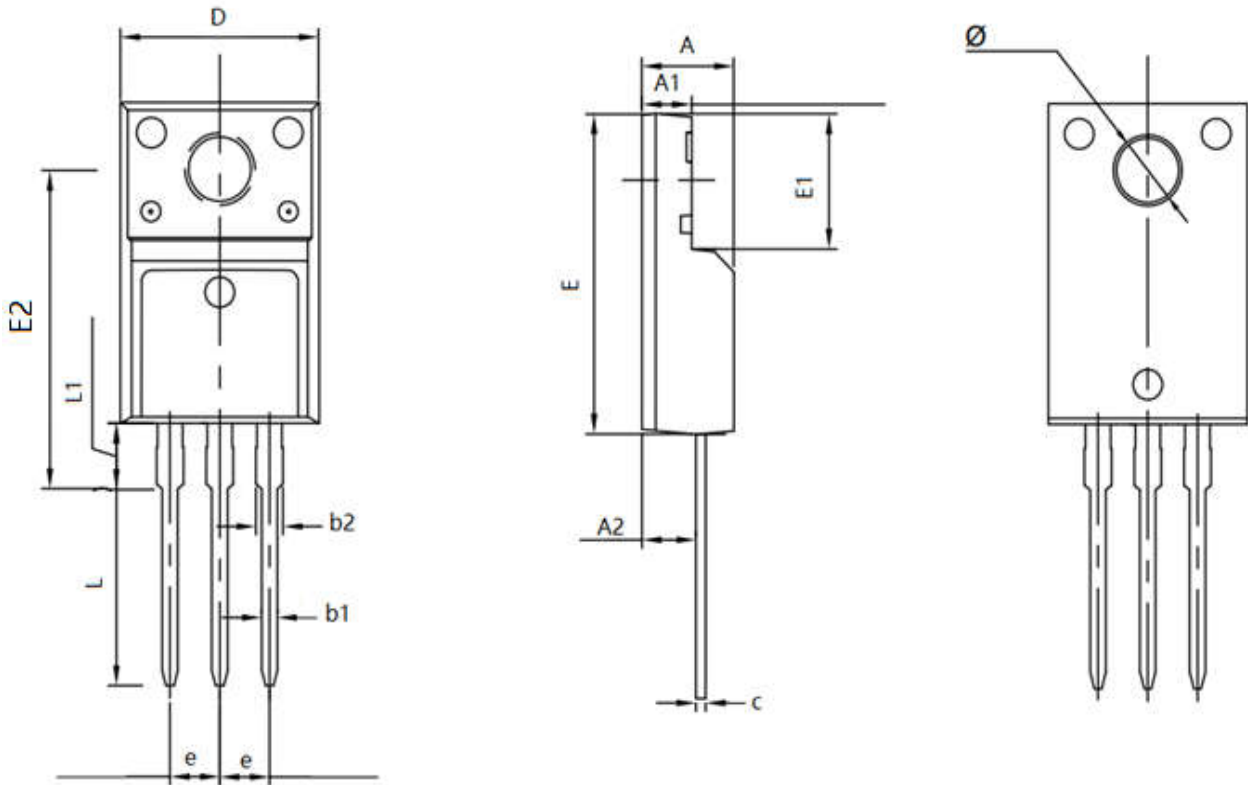
## TO-220-3L-C Package Information



Symbol	Dimensions In Millimeters		Dimensions In Inches	
	Min.	Max.	Min.	Max.
A	4.400	4.600	0.173	0.181
A1	2.250	2.550	0.089	0.100
b	0.710	0.910	0.028	0.036
b1	1.170	1.370	0.046	0.054
c	0.330	0.650	0.013	0.026
c1	1.200	1.400	0.047	0.055
D	9.910	10.250	0.390	0.404
E	8.9500	9.750	0.352	0.384
E1	12.650	12.950	0.498	0.510
e	2.540 TYP.		0.100 TYP.	
e1	4.980	5.180	0.196	0.204
F	2.650	2.950	0.104	0.116
H	7.900	8.100	0.311	0.319
h	0.000	0.300	0.000	0.012
L	12.900	13.400	0.508	0.528
L1	2.850	3.250	0.112	0.128
V	7.500 REF.		0.295 REF.	
Φ	3.400	3.800	0.134	0.150



## TO-220F Package Information



Symbol	Dimensions In Millimeters		Dimensions In Inches	
	Min.	Max.	Min.	Max.
A	4.500	4.900	0.177	0.193
A1	2.340	2.740	0.092	0.108
A2	2.560	2.960	0.101	0.117
b1	0.700	0.900	0.028	0.035
b2	1.180	1.580	0.046	0.062
c	0.400	0.600	0.016	0.024
D	9.960	10.360	0.392	0.408
E	15.670	15.970	0.617	0.629
E1	6.500	6.900	0.256	0.272
E2	15.500	16.100	0.610	0.634
e	2.540 TYP		0.100 TYP	
Φ	3.080	3.280	0.121	0.129
L	12.640	13.240	0.498	0.521
L1	3.030	3.430	0.119	0.135

## ATTENTION

QIAOXIN assumes no responsibility for equipment failures that result from using products at values that exceed, even momentarily, rated values (such as maximum ratings, operating condition ranges, or other parameters) listed in products specifications of any and all QIAOXIN products described or contained herein. QIAOXIN products are not designed for use in life support appliances, devices or systems where malfunction of these products can be reasonably expected to result in personal injury. Reproduction in whole or in part is prohibited without the prior written consent of the copyright owner. QIAOXIN reserves the right to make changes to information published in this document, including without limitation specifications and product descriptions, at any time and without notice. This document supersedes and replaces all information supplied prior to the publication hereof.