

## Surface Mount 2-Electrode Gas Discharge Tube (GDT)

### QX800-80KA

#### Description

Gas discharge Tubes (GDT) are classical components for protecting the installations of the telecommunications. It is essential that IT and telecommunications systems -with their high-grade but sensitive electronic circuits - be protected by arresters. They are thus fitted at the input of the power supply system together with varistors and at the connection points to telecommunication lines. They have become equally indispensable for protecting base stations in mobile telephone systems as well as extensive cable television (CATV) networks with their repeaters and distribution systems.

These protective components are also indispensable in other sectors, In AC power transmission systems, they are often used with current-limiting varistors, In customer premises equipment such as DSL modems, WLAN routers, TV sets and cable modems In air-conditioning equipment, the integral black-box concept offers graduated protection by combining arresters with varistors, PTC, diodes and inductor.



#### Schematic Symbol

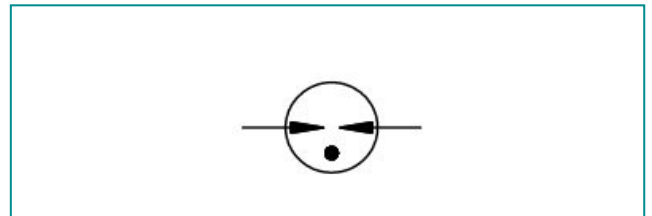

#### Features

- ◆ Non-Radioactive
- ◆ RoHS compliant
- ◆ Low insertion loss
- ◆ Excellent response to fast rising transients
- ◆ Ultra low capacitance
- ◆ 80KA surge capability tested with 8/20  $\mu$  s pulse as defined by IEC 61000-4-5

#### Applications

- ◆ Communication equipment
- ◆ Power supplies
- ◆ Type I (class B)
- ◆ Medical electronics
- ◆ Satellite and CATV equipment
- ◆ 80KA surge capability tested with 8/20  $\mu$  s pulse as defined by IEC 61000-4-5

#### Dimensions Unit: mm

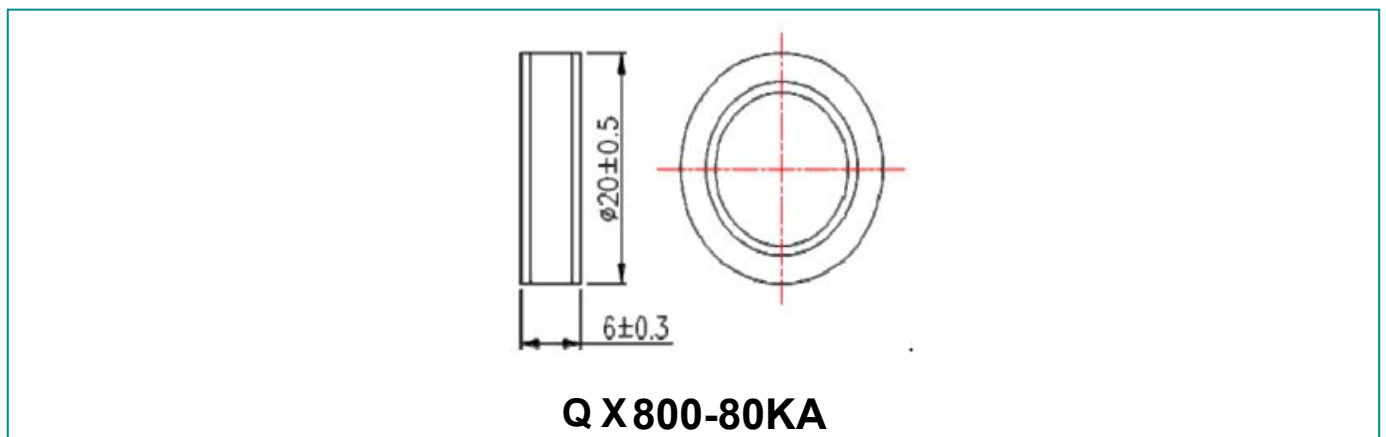

## Surface Mount 2-Electrode Gas Discharge Tube (GDT)

**QX800-80KA**

### Electrical Characteristics

Part Number	Maximum Impulse Spark-over Voltage		Minimum Insulation Resistance	Maximum Capacitance	Arc Voltage	Service Life	
	@100V/ $\mu$ s	@1KV/ $\mu$ s				Nominal Impulse Discharge Current	Max Impulse Discharge Current
QX800-80KA	800	<1600	>1 G $\Omega$ (at 100V)	<7pF	~15V	80KA	100KA

### Electrical Rating

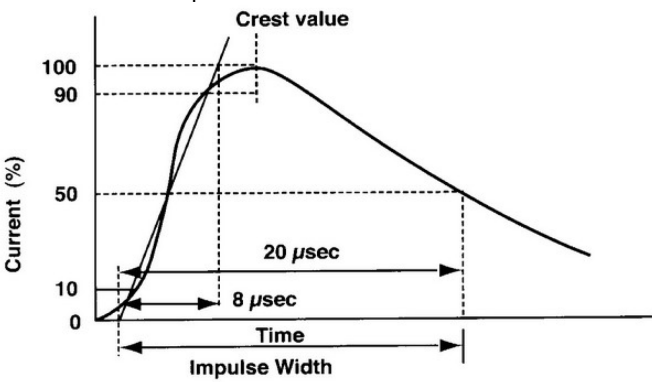
Item	Test Condition / Description	Requirement
<b>DC Spark-over Voltage</b>	The voltage is measured with a slowly rate of rise $dv / dt=100V/s$	To meet the specified value
<b>Impulse Spark-over Voltage</b>	The maximum impulse spark-over voltage is measured with a rise time of $dv / dt=100V//s$ or $1KV/ s$	
<b>Insulation Resistance</b>	The resistance of gas tube shall be measured each terminal each other terminal, please see above spec.	
<b>Capacitance</b>	The capacitance of gas tube shall be measured each terminal to each other terminal. Test frequency :1MHz	
<b>Nominal Impulse Discharge Current</b>	The maximum current applying a waveform of 8/20 $\mu$ s that can be applied across the terminals of the gas tube. One hour after the test is completed, re-testing of the DC spark-over voltage does not exceed $\pm 30\%$ of the nominal DC spark-over voltage. Dwell time between pulses is 3 minutes. 	
<b>Nominal Alternating Discharge Current</b>	Rated RMS value of AC current at 50Hz, 1 sec. 10 times. Intervals: 3min. The DC spark-over voltage does not exceed $\pm 30\%$ of the nominal DC spark-over voltage. IR > 10 <sup>8</sup> ohms.	

## Surface Mount 2-Electrode Gas Discharge Tube (GDT)

**QX800-80KA**

### Recommended soldering profile

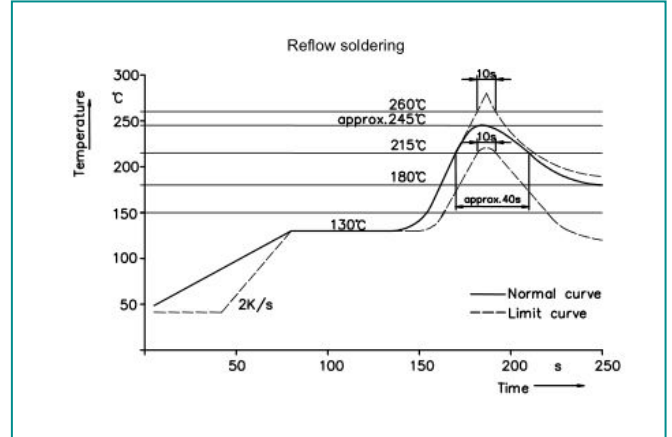
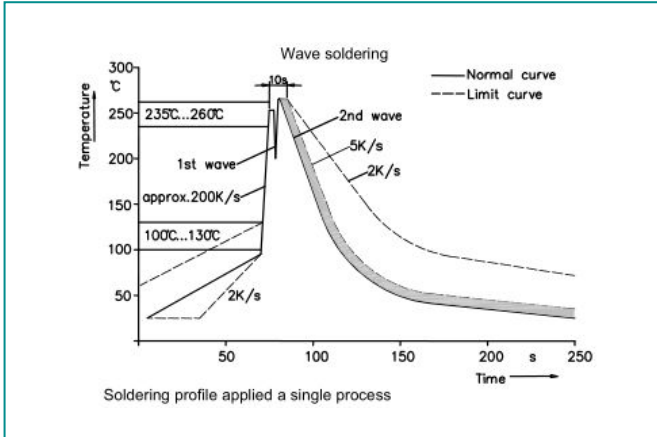

### Soldering Parameters - Hand Soldering

Solder Iron Temperature: 350° C +/-5° C

Heating Time: 5 seconds max.

### Part Numbering

**QX 800 - 80KA**

